

Dual Smart Battery System Manager

FEATURES

- **SMBus Charger/Selector for Two Smart Batteries***
- **Voltage and Current Accuracy within 0.2% of Value Reported by Battery**
- **Simplifies Construction of “Smart Battery System Manager”**
- **Includes All SMBus Charger V1.1 Safety Features**
- **Supports Autonomous Operation without a Host**
- **Allows Both Batteries to Discharge Simultaneously into Single Load with Low Loss (Ideal Diode)**
- **SMBus Switching for Dual Batteries with Alarm Monitoring for Charging Battery at All Times**
- **Pin Programmable Limits for Maximum Charge Current and Voltage Improve Safety**
- **Fast Autonomous PowerPath™ Switching (<10μs)**
- **Low Loss Simultaneous Charging of Two Batteries**
- **>95% Efficient Synchronous Buck Charger**
- **AC Adapter Current Limiting* Maximizes Charge Rate**
- **SMBus Accelerator Improves SMBus Timing****
- **Available in 48-Lead TSSOP Package**

APPLICATIONS

- Portable Computers and Instruments
- Standalone Dual Smart Battery Chargers
- Battery Backup Systems

DESCRIPTION

The **LTC®1760** Smart Battery System Manager is a highly-integrated SMBus Level 3 battery charger and selector intended for products using dual smart batteries. Three SMBus interfaces allow the LTC1760 to servo to the internal voltage and currents measured by the batteries while allowing an SMBus Host device to monitor either battery’s status. Charging accuracy is determined by the battery’s internal voltage and current measurements, typically better than $\pm 0.2\%$.

A proprietary PowerPath architecture supports simultaneous charging or discharging of both batteries. Typical battery run times are extended by up to 10%, while charging times are reduced by up to 50%. The LTC1760 automatically switches between power sources in less than 10μs to prevent power interruption upon battery or wall adapter removal.

The LTC1760 implements all elements of a version 1.1 “Smart Battery System Manager” except for the generation of composite battery information. An internal multiplexer cleanly switches the SMBus Host to either of the two attached Smart Batteries without generating partial messages to batteries or SMBus Host. Thermistors on both batteries are automatically monitored for temperature and disconnection information (SafetySignal).

LT, LT, LTC, LTM, Linear Technology and the Linear Logo are registered trademarks and PowerPath is a trademark of Analog Devices, Inc. All other trademarks are the property of their respective owners. Protected by U.S. Patents including *5723970 **6650174.

TYPICAL APPLICATION

Dual Battery Charger/Selector System Architecture

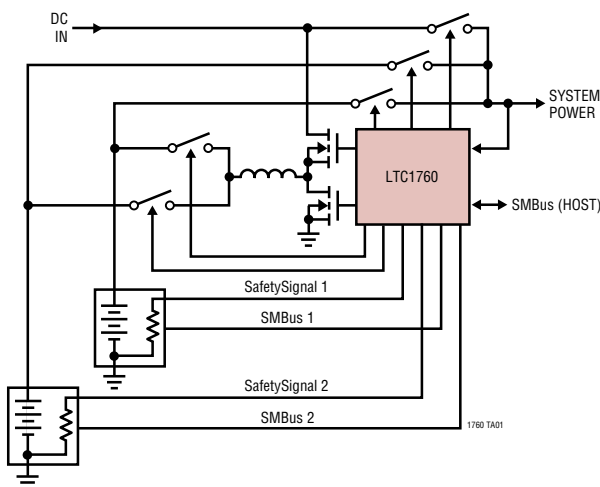

Dual vs Sequential Charging

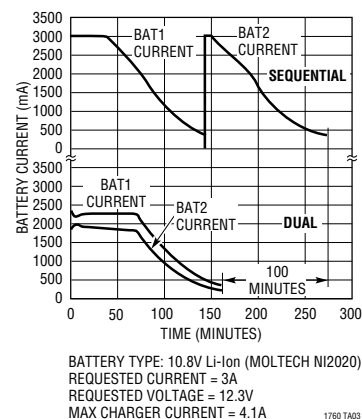

LTC1760

ABSOLUTE MAXIMUM RATINGS

(Note 1)

DCIN, SCP, SCN, CLP,	
V _{PLUS} , SW to GND	-0.3V to 32V
SCH1, SCH2 to GND	-0.3V to 28V
BOOST to GND	-0.3V to 37V
CSP, CSN, BAT1, BAT2 to GND	-0.3V to 28V
LOPWR, DCDIV to GND	-0.3V to 10V
V _{CC2} , V _{DDS} to GND	-0.3V to 7V
SDA1, SDA2, SDA, SCL1,	
SCL2, SCL, <u>SMBALERT</u> to GND	-0.3V to 7V
MODE to GND	-0.3V to V _{CC2} +0.3V
COMP1 to GND	-0.3V to 5V
Maximum DC Current Into Pin	
SDA1, SDA2, SDA, SCL1, SCL2, SCL	±3mA
TH1A, TH2A	-5mA
TH1B, TH2B	-102µA
Operating Junction Temperature Range	
(Note 6)	-40°C to 125°C
Storage Temperature	-65°C to 150°C
Lead Temperature (Soldering, 10 sec)	300°C

PIN CONFIGURATION

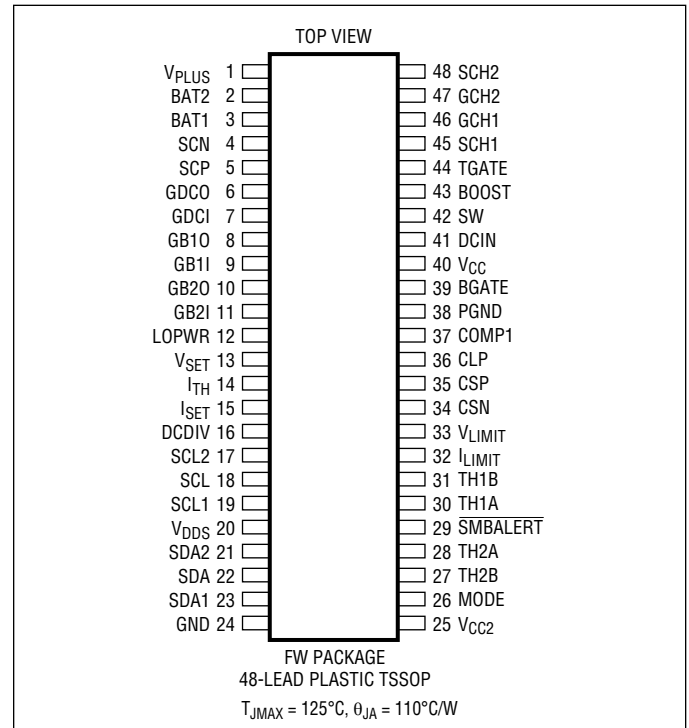

ORDER INFORMATION

(<http://www.linear.com/product/LTC1760#orderinfo>)

LEAD FREE FINISH	TAPE AND REEL	PART MARKING	PACKAGE DESCRIPTION	TEMPERATURE RANGE
LTC1760CFW#PBF	LTC1760CFW#TRPBF	LTC1760CFW	48-Lead Plastic TSSOP	0°C to 85°C
LTC1760IFW#PBF	LTC1760IFW#TRPBF	LTC1760IFW	48-Lead Plastic TSSOP	-40°C to 125°C

Consult LTC Marketing for parts specified with wider operating temperature ranges.

Consult LTC Marketing for information on non-standard lead based finish parts.

For more information on lead free part marking, go to: <http://www.linear.com/leadfree/>

For more information on tape and reel specifications, go to: <http://www.linear.com/tapeandree/>. Some packages are available in 500 unit reels through designated sales channels with #TRMPBF suffix.

ELECTRICAL CHARACTERISTICS The ● denotes the specifications which apply over the full operating junction temperature range, otherwise specifications are at $T_A = 25^\circ\text{C}$ (Note 6). $V_{\text{DCIN}} = 20\text{V}$, $V_{\text{BAT1}} = 12\text{V}$, $V_{\text{BAT2}} = 12\text{V}$, $V_{\text{VDD5}} = 3.3\text{V}$, $V_{\text{VCC2}} = 5.2\text{V}$ unless otherwise noted.

SYMBOL	PARAMETER	CONDITIONS	MIN	TYP	MAX	UNITS	
Supply and Reference							
	DCIN Operating Range	DCIN Selected	6		28	V	
I_{CH0} I_{CH1}	DCIN Operating Current	Not Charging (DCIN Selected) (Note 10) Charging (DCIN Selected) (Note 10)		1 1.3	1.5 2	mA mA	
$I_{\text{VCC2_AC1}}$ $I_{\text{VCC2_AC0}}$	VCC2 Operating Current	AC Present (Note 11) AC Not Present (Note 11)		0.75 75	1 100	mA μA	
	Battery Operating Voltage Range	Battery Selected, PowerPath Function Battery Selected, Charging Function (Note 2)	6 0		28 28	V V	
I_{BAT}	Battery Drain Current	Battery Selected, Not Charging, $V_{\text{DCIN}} = 0\text{V}$ (Note 10)		175		μA	
V_{FDC} V_{FB1} V_{FB2} V_{FSCN}	VPLUS Diodes Forward Voltage: DCIN to VPLUS BAT1 to VPLUS BAT2 to VPLUS SCN to VPLUS	$I_{\text{VCC}} = 10\text{mA}$ $I_{\text{VCC}} = 0\text{mA}$ $I_{\text{VCC}} = 0\text{mA}$ $I_{\text{VCC}} = 0\text{mA}$		0.8 0.7 0.7 0.7		V V V V	
V_{VLO}	Undervoltage Lockout Threshold	VPLUS Ramping Down, Measured at VPLUS to GND	●	3	5	V	
V_{VCC}	VCC Regulator Output Voltage		●	4.9	5.2	5.5	V
V_{LDR}	VCC Load Regulation	No External Connection Beyond Applications Shown Herein		0.2	1	%	
Switching Regulator							
V_{TOL}	Voltage Accuracy	With Respect to Voltage Reported by Battery $V_{\text{CHMIN}} < \text{Requested Voltage} < V_{\text{LIMIT}}$	●	-32	32	mV	
I_{TOL}	Current Accuracy	With Respect to Current Reported by Battery $4\text{mV}/R_{\text{SENSE}} < \text{Requested Current} < I_{\text{LIMIT}} (\text{Min})$ (Note 12) $R_{\text{LIMIT}} = 0$ (Short to GND) $R_{\text{LIMIT}} = 10\text{k} \pm 1\%$ $R_{\text{LIMIT}} = 33\text{k} \pm 1\%$ $R_{\text{LIMIT}} = \text{Open}$ (or Short I_{LIMIT} to VCC2)	● ● ● ●	-2 -4 -8 -8	2 4 8 8	mA mA mA mA	
f_{OSC}	Regulator Switching Frequency			255	300	345	kHz
f_{DO}	Regulator Switching Frequency in Low Dropout Mode	Duty Cycle $\geq 99\%$		20	25		kHz
DC_{MAX}	Regulator Maximum Duty Cycle			99	99.5		%
I_{MAX}	Maximum Current Sense Threshold	$V_{\text{ITH}} = 2.2\text{V}$		140	155	190	mV
I_{SNS}	CA1 Input Bias Current	$V_{\text{CSP}} = V_{\text{CSN}} > 5\text{V}$			150		μA
CMSL	CA1 Input Common Mode Low			0			V
CMSH	CA1 Input Common Mode High				$V_{\text{DCIN}} - 0.2$		V
V_{CL1}	CL1 Turn-On Threshold	C-Grade (Note 6) I-Grade (Note 6)	● ●	95 94 90	100 100 100	105 108 108	mV mV mV
$\text{TG } t_r$ $\text{TG } t_f$	TGATE Transition Time: TGATE Rise Time TGATE Fall Time	$C_{\text{LOAD}} = 3300\text{pF}$, 10% to 90% $C_{\text{LOAD}} = 3300\text{pF}$, 10% to 90%			50 50	90 90	ns ns
$\text{BG } t_r$ $\text{BG } t_f$	BGATE Transition Time BGATE Rise Time BGATE Fall Time	$C_{\text{LOAD}} = 3300\text{pF}$, 10% to 90% $C_{\text{LOAD}} = 3300\text{pF}$, 10% to 90%			50 40	90 80	ns ns

ELECTRICAL CHARACTERISTICS

The ● denotes the specifications which apply over the full operating junction temperature range, otherwise specifications are at $T_A = 25^\circ\text{C}$ (Note 6). $V_{\text{DCIN}} = 20\text{V}$, $V_{\text{BAT1}} = 12\text{V}$, $V_{\text{BAT2}} = 12\text{V}$, $V_{\text{VDD5}} = 3.3\text{V}$, $V_{\text{VCC2}} = 5.2\text{V}$ unless otherwise noted.

SYMBOL	PARAMETER	CONDITIONS	MIN	TYP	MAX	UNITS	
Trip Points							
V_{TR}	DCDIV/LOPWR Threshold	V_{DCDIV} or V_{LOPWR} Falling					
		C-Grade (Note 6)	●	1.166	1.19	1.215	V
		I-Grade (Note 6)	●	1.162	1.19	1.215	V
V_{THYS}	DCDIV/LOPWR Hysteresis Voltage	V_{DCDIV} or V_{LOPWR} Rising		30		mV	
I_{BVT}	DCDIV/LOPWR Input Bias Current	V_{DCDIV} or $V_{\text{LOPWR}} = 1.19\text{V}$		20	200	nA	
V_{TSC}	Short-Circuit Comparator Threshold	$V_{\text{SCP}} - V_{\text{SCN}}$, $V_{\text{CC}} \geq 5\text{V}$					
		C-Grade (Note 6)	●	90	100	115	mV
		I-Grade (Note 6)	●	88	100	115	mV
V_{FTO}	Fast PowerPath Turn-Off Threshold	V_{DCDIV} Rising from V_{CC}		6	7	7.9	V
V_{OVSD}	Overvoltage Shutdown Threshold as a Percent of Programmed Charger Voltage	V_{SET} Rising from 0.8V until TGATE and BGATE Stop Switching		107		%	

DACs

I_{RES}	I_{DAC} Resolution	Guaranteed Monotonic		10		Bits		
t_{IP} t_{LOW}	I_{DAC} Pulse Period: Normal Mode Wake-Up Mode			6	10	15	μs ms	
	Charging Current Granularity	$R_{\text{LIMIT}} = 0$ (Short I_{LIMIT} to GND) $R_{\text{LIMIT}} = 10\text{k} \pm 1\%$ $R_{\text{LIMIT}} = 33\text{k} \pm 1\%$ $R_{\text{LIMIT}} = \text{Open}$ (or Short I_{LIMIT} to V_{CC2})			1 2 4 4	mA mA mA mA		
$I_{\text{WAKE_UP}}$	Wake-Up Charging Current (Note 5)			60	80	100	mA	
I_{LIMIT}	Charging Current Limit	C-Grade (Note 6)						
		$R_{\text{LIMIT}} = 0$ (Short I_{LIMIT} to GND)	●	980	1000	1070	mA	
		$R_{\text{LIMIT}} = 10\text{k} \pm 1\%$	●	1960	2000	2140	mA	
		$R_{\text{LIMIT}} = 33\text{k} \pm 1\%$	●	2490	3000	3210	mA	
		$R_{\text{LIMIT}} = \text{Open}$ (or Short I_{LIMIT} to V_{CC2})	●	3920	4000	4280	mA	
		I-Grade (Note 6)						
		$R_{\text{LIMIT}} = 0$ (Short I_{LIMIT} to GND)	●	930	1000	1110	mA	
		$R_{\text{LIMIT}} = 10\text{k} \pm 1\%$	●	1870	2000	2220	mA	
	$R_{\text{LIMIT}} = 33\text{k} \pm 1\%$	●	2380	3000	3320	mA		
	$R_{\text{LIMIT}} = \text{Open}$ (or Short I_{LIMIT} to V_{CC2})	●	3750	4000	4430	mA		
V_{RES}	V_{DAC} Resolution	Guaranteed Monotonic ($5\text{V} < V_{\text{BAT}} < 25\text{V}$)		11		Bits		
V_{STEP}	V_{DAC} Granularity			16		mV		
V_{LIMIT}	Charging Voltage Limit (Note 7)	$R_{\text{VLIMIT}} = 0$ (Short V_{LIMIT} to GND)	●	8400	8432	8464	mV	
		$R_{\text{VLIMIT}} = 10\text{k} \pm 1\%$	●	12608	12640	12672	mV	
		$R_{\text{VLIMIT}} = 33\text{k} \pm 1\%$	●	16832	16864	16896	mV	
		$R_{\text{VLIMIT}} = 100\text{k} \pm 1\%$	●	21024	21056	21088	mV	
		$R_{\text{VLIMIT}} = \text{Open}$ (or Short V_{LIMIT} to V_{CC2}) (Note 13)	●		32768		mV	

Charge MUX Switches

t_{ONC}	GCH1/GCH2 Turn-On Time	$V_{\text{GCHX}} - V_{\text{SCHX}} > 3\text{V}$, $C_{\text{LOAD}} = 3000\text{pF}$		5	10	ms
t_{OFFC}	GCH1/GCH2 Turn-Off Time	$V_{\text{GCHX}} - V_{\text{SCHX}} < 1\text{V}$, from Time of $V_{\text{CSN}} < V_{\text{BATX}} - 30\text{mV}$, $C_{\text{LOAD}} = 3000\text{pF}$		15		μs
V_{CON}	CH Gate Clamp Voltage GCH1 GCH2	$I_{\text{LOAD}} = 1\mu\text{A}$				
		$V_{\text{GCH1}} - V_{\text{SCH1}}$ $V_{\text{GCH2}} - V_{\text{SCH2}}$		5	5.8	7

ELECTRICAL CHARACTERISTICS The ● denotes the specifications which apply over the full operating junction temperature range, otherwise specifications are at $T_A = 25^\circ\text{C}$ (Note 6). $V_{\text{DCIN}} = 20\text{V}$, $V_{\text{BAT1}} = 12\text{V}$, $V_{\text{BAT2}} = 12\text{V}$, $V_{\text{VDDS}} = 3.3\text{V}$, $V_{\text{VCC2}} = 5.2\text{V}$ unless otherwise noted.

SYMBOL	PARAMETER	CONDITIONS	MIN	TYP	MAX	UNITS	
V_{COFF}	CH Gate Off Voltage	$I_{\text{LOAD}} = 10\mu\text{A}$					
	GCH1	$V_{\text{GCH1}} - V_{\text{SCH1}}$	-0.8	-0.4	0	V	
	GCH2	$V_{\text{GCH2}} - V_{\text{SCH2}}$	-0.8	-0.4	0	V	
V_{TOC}	CH Switch Reverse Turn-Off Voltage	$V_{\text{BATX}} - V_{\text{CSN}}$, $5\text{V} \leq V_{\text{BATX}} \leq 28\text{V}$	●	5	20	40	mV
		C-Grade (Note 6)	●	2	20	40	mV
		I-Grade (Note 6)					
V_{FC}	CH Switch Forward Regulation Voltage	$V_{\text{CSN}} - V_{\text{BATX}}$, $5\text{V} \leq V_{\text{BATX}} \leq 28\text{V}$	●	15	35	60	mV
$I_{\text{OC(SRC)}}$ $I_{\text{OC(SNK)}}$	GCH1/GCH2 Active Regulation:	$V_{\text{GCHX}} - V_{\text{SCHX}} = 1.5\text{V}$					
	Max Source Current			-2		μA	
	Max Sink Current			2		μA	
V_{CHMIN}	BATX Voltage Below Which Charging is Inhibited	(Note 14)		3.5	4.7	V	

PowerPath Switches

t_{DLY}	Blanking Period after UVLO Trip	Switches Held Off		250		ms	
t_{PPB}	Blanking Period after LOPWR Trip	Switches in 3-Diode Mode		1		sec	
t_{ONPO}	GB10/GB20/GDCO Turn-On Time	$V_{\text{GS}} < -3\text{V}$, from Time of Battery/DC Removal, or LOPWR Indication, $C_{\text{LOAD}} = 3000\text{pF}$	●	5	10	μs	
t_{OFFPO}	GB10/GB20/GDCO Turn-Off Time	$V_{\text{GS}} > -1\text{V}$, from Time of Battery/DC Removal, or LOPWR Indication, $C_{\text{LOAD}} = 3000\text{pF}$	●	3	7	μs	
V_{PONO}	Output Gate Clamp Voltage	GB10	$I_{\text{LOAD}} = 1\mu\text{A}$	4.75	6.25	7	V
		Highest (V_{BAT1} or V_{SCP}) - V_{GB10}					
		GB20	Highest (V_{BAT2} or V_{SCP}) - V_{GB20}	4.75	6.25	7	V
	GDCO	Highest (V_{DCIN} or V_{SCP}) - V_{GDCO}	4.75	6.25	7	V	
V_{POFFO}	Output Gate Off Voltage	GB10	$I_{\text{LOAD}} = -25\mu\text{A}$		0.18	0.25	V
		Highest (V_{BAT1} or V_{SCP}) - V_{GB10}					
		GB20	Highest (V_{BAT2} or V_{SCP}) - V_{GB20}		0.18	0.25	V
	GDCO	Highest (V_{DCIN} or V_{SCP}) - V_{GDCO}		0.18	0.25	V	
V_{TOP}	PowerPath Switch Reverse Turn-Off Voltage	$V_{\text{SCP}} - V_{\text{BATX}}$ or $V_{\text{SCP}} - V_{\text{DCIN}}$					
		$6\text{V} \leq V_{\text{SCP}} \leq 28\text{V}$	●	5	20	60	mV
		C-Grade (Note 6)	●	2	20	60	mV
		I-Grade (Note 6)					
V_{FP}	PowerPath Switch Forward Regulation Voltage	$V_{\text{BATX}} - V_{\text{SCP}}$ or $V_{\text{DCIN}} - V_{\text{SCP}}$	●	0	25	50	mV
		$6\text{V} \leq V_{\text{SCP}} \leq 28\text{V}$					
$I_{\text{OP(SRC)}}$ $I_{\text{OP(SNK)}}$	GDCI/GB11/GB21 Active Regulation:	(Note 3)					
	Source Current			-4		μA	
	Sink Current			75		μA	
t_{ONPI}	Gate B11/B21/DCI Turn-On Time	$V_{\text{GS}} < -3\text{V}$, $C_{\text{LOAD}} = 3000\text{pF}$ (Note 4)		300		μs	
t_{OFFPI}	Gate B11/B21/DCI Turn-Off Time	$V_{\text{GS}} > -1\text{V}$, $C_{\text{LOAD}} = 3000\text{pF}$ (Note 4)		10		μs	
V_{PONI}	Input Gate Clamp Voltage	GB11	$I_{\text{LOAD}} = 1\mu\text{A}$	4.75	6.7	7.5	V
		Highest (V_{BAT1} or V_{SCP}) - V_{GB11}					
		GB21	Highest (V_{BAT2} or V_{SCP}) - V_{GB21}	4.75	6.7	7.5	V
	GDCI	Highest (V_{DCIN} or V_{SCP}) - V_{GDCI}	4.75	6.7	7.5	V	
V_{POFFI}	Input Gate Off Voltage	GB11	$I_{\text{LOAD}} = -25\mu\text{A}$		0.18	0.25	V
		Highest (V_{BAT1} or V_{SCP}) - V_{GB11}					
		GB21	Highest (V_{BAT2} or V_{SCP}) - V_{GB21}		0.18	0.25	V
	GDCI	Highest (V_{DCIN} or V_{SCP}) - V_{GDCI}		0.18	0.25	V	

ELECTRICAL CHARACTERISTICS

The ● denotes the specifications which apply over the full operating junction temperature range, otherwise specifications are at $T_A = 25^\circ\text{C}$ (Note 6). $V_{\text{DCIN}} = 20\text{V}$, $V_{\text{BAT1}} = 12\text{V}$, $V_{\text{BAT2}} = 12\text{V}$, $V_{\text{VDD5}} = 3.3\text{V}$, $V_{\text{VCC2}} = 5.2\text{V}$ unless otherwise noted.

SYMBOL	PARAMETER	CONDITIONS	MIN	TYP	MAX	UNITS	
Thermistor							
	Thermistor Trip COLD-RANGE to OVER-RANGE	$C_{\text{LOAD(MAX)}} = 300\text{pF}$ (Note 9) $R1A = R2A = 1130\Omega \pm 1\%$ $R1B = R2B = 54900\Omega \pm 1\%$	●	95	100	105	$\text{k}\Omega$
	Thermistor Trip IDEAL-RANGE to COLD-RANGE	$C_{\text{LOAD(MAX)}} = 300\text{pF}$ (Note 9) $R1A = R2A = 1130\Omega \pm 1\%$ $R1B = R2B = 54900\Omega \pm 1\%$	●	28.5	30	32.5	$\text{k}\Omega$
	Thermistor Trip HOT-RANGE to IDEAL-RANGE	$C_{\text{LOAD(MAX)}} = 300\text{pF}$ (Note 9) $R1A = R2A = 1130\Omega \pm 1\%$ $R1B = R2B = 54900\Omega \pm 1\%$ C-Grade (Note 6) I-Grade (Note 6)	● ●	2.85 2.83	3	3.15	$\text{k}\Omega$ $\text{k}\Omega$
	Thermistor Trip UNDER-RANGE to HOT-RANGE	$C_{\text{LOAD(MAX)}} = 300\text{pF}$ (Note 9) $R1A = R2A = 1130\Omega \pm 1\%$ $R1B = R2B = 54900\Omega \pm 1\%$	●	425	500	575	Ω
Logic Levels							
	SCL/SCL1/SCL2/SDA/SDA1/ SDA2 Input Low Voltage (V_{IL})		●			0.8	V
	SCL/SCL1/SCL2/SDA/SDA1/ SDA2 Input High Voltage (V_{IH})		●	2.1			V
	SCL/SCL1/SCL2/SDA/SDA1/ SDA2 Input Leakage Current	$V_{\text{SDA}}, V_{\text{SCL}}, V_{\text{SDA1}}, V_{\text{SCL1}},$ $V_{\text{SDA2}}, V_{\text{SCL2}} = 0.8\text{V}$	●	-5		5	μA
	SCL/SCL1/SCL2/SDA/SDA1/ SDA2 Input Leakage Current	$V_{\text{SDA}}, V_{\text{SCL}}, V_{\text{SDA1}}, V_{\text{SCL1}}, V_{\text{SDA2}},$ $V_{\text{SCL2}} = 2.1\text{V}$	●	-5		5	μA
I_{PULLUP}	SCL1/SDA1/SCL2/SDA2 Pull-Up Current When Not Connected to SMBus Host	$V_{\text{SCL1}}, V_{\text{SDA1}}, V_{\text{SCL2}}, V_{\text{SDA2}} = 0.4\text{V}$ $V_{\text{VCC2}} = 4.85\text{V}$ and 5.55V (Current is Through Internal Series Resistor and Schottky to V_{CC2})		165	220	350	μA
	SCL1/SDA1/SCL2/SDA2 Series Impedance to Host SMBus	$V_{\text{SDA1}}, V_{\text{SCL1}}, V_{\text{SDA2}}, V_{\text{SCL2}} = 0.8\text{V}$	●			300	Ω
	SCL/SDA Output Low Voltage (V_{OL}). LTC1760 Driving the Pin	$I_{\text{PULLUP}} = 350\mu\text{A}$	●			0.4	V
	SCL1/SDA1/SCL2/SDA2 Pullup Output Low Voltage (V_{OL}). LTC1760 Driving the Pin with Battery SMBus not Connected to Host SMBus	I_{PULLUP} Internal to LTC1760	●			0.4	V
	SCL1/SDA1/SCL2/SDA2 Output Low Voltage (V_{OL}). LTC1760 Driving the Pin with Battery SMBus Connected to Host SMBus	$I_{\text{PULLUP}} = 350\mu\text{A}$ on Host Side	●			0.4	V
	SCL/SCL1/SCL2/SDA/SDA1/ SDA2/ SMBALERT Power Down Leakage	$V_{\text{VCC2}} = 0\text{V}$, $V_{\text{VDD5}} = 0\text{V}$, $V_{\text{SCL}}, V_{\text{SCL1}}, V_{\text{SCL2}}, V_{\text{SDA}},$ $V_{\text{SDA1}}, V_{\text{SDA2}}, V_{\text{SMBALERT}} = 5.5\text{V}$	●			2	μA
	SMBALERT Output Low Voltage (V_{OL})	$I_{\text{PULLUP}} = 500\mu\text{A}$	●			0.4	V
	SMBALERT Output Pull-Up Current	$V_{\text{SMBALERT}} = 0.4\text{V}$		3.5	10	17.5	μA
$V_{\text{IL_VDD5}}$	V_{D5} Input Low Voltage (V_{IL})		●			1.5	V
$V_{\text{IH_VDD5}}$	V_{D5} Input High Voltage (V_{IH})		●	2.6			V
	V_{D5} Operating Voltage		●	3		5.5	V
	V_{D5} Operating Current	$V_{\text{SCL}}, V_{\text{SDA}} = V_{\text{VDD5}}, V_{\text{VDD5}} = 5\text{V}$				18	μA
$V_{\text{IL_MODE}}$	MODE Input Low Voltage (V_{IL})	$V_{\text{VCC2}} = 4.85\text{V}$	●			$V_{\text{VCC2}} \cdot 0.3$	V

ELECTRICAL CHARACTERISTICS The ● denotes the specifications which apply over the full operating junction temperature range, otherwise specifications are at $T_A = 25^\circ\text{C}$ (Note 6). $V_{\text{DCIN}} = 20\text{V}$, $V_{\text{BAT1}} = 12\text{V}$, $V_{\text{BAT2}} = 12\text{V}$, $V_{\text{VDDS}} = 3.3\text{V}$, $V_{\text{VCC2}} = 5.2\text{V}$ unless otherwise noted.

SYMBOL	PARAMETER	CONDITIONS	MIN	TYP	MAX	UNITS
$V_{\text{IH_MODE}}$	MODE Input High Voltage (V_{IH})	$V_{\text{VCC2}} = 4.85\text{V}$	● $V_{\text{VCC2}} \cdot 0.7$			V
	MODE Input Current (I_{IH})	MODE = $V_{\text{VCC2}} \cdot 0.7\text{V}$, $V_{\text{VCC2}} = 4.85\text{V}$	● -1		1	μA
	MODE Input Current (I_{IL})	MODE = $V_{\text{VCC2}} \cdot 0.3\text{V}$, $V_{\text{VCC2}} = 4.85\text{V}$	● -1		1	μA

Charger Timing

t_{TIMEOUT}	Timeout for Wake-Up Charging and Controlled Charging		● 140	175	210	sec
t_{QUERY}	Sampling Rate Used by the LTC1760 to Update Charging Parameters			1		sec

SMBus Timing

	SCL Serial-Clock High Period (t_{HIGH})	At $I_{\text{PULLUP}} = 350\mu\text{A}$, $C_{\text{LOAD}} = 150\text{pF}$ (Note 8)	● 4			μs
	SCL Serial-Clock Low Period (t_{LOW})	At $I_{\text{PULLUP}} = 350\mu\text{A}$, $C_{\text{LOAD}} = 150\text{pF}$ (Note 8)	● 4.7			μs
	SDA/SCL Rise Time (t_r)	$C_{\text{LOAD}} = 150\text{pF}$, $\text{RPU} = 9.31\text{k}$ (Note 8)	●		1000	ns
	SDA/SCL Fall Time (t_f)	$C_{\text{LOAD}} = 150\text{pF}$, $\text{RPU} = 9.31\text{k}$ (Note 8)	●		300	ns
	SMBus Accelerator Trip Voltage Range		● 0.8		1.42	V
	Start-Condition Setup Time ($t_{\text{SU:STA}}$)		● 4.7			μs
	Start-Condition Hold Time ($t_{\text{HD:STA}}$)		● 4			μs
	SDA to SCL Rising-Edge Setup Time ($t_{\text{SU:DAT}}$)		● 250			ns
	SDA to SCL Falling-Edge Hold Time, Slave Clocking in Data ($t_{\text{HD:DAT}}$)		● 300			ns
$t_{\text{TIMEOUT_SMB}}$	The LTC1760 will Release the SMBus and Terminate the Current Master or Slave Command if the Command is not Completed Before this Time		● 25		35	ms

Note 1: Stresses beyond those listed under Absolute Maximum Ratings may cause permanent damage to the device. Exposure to any Absolute Maximum Rating condition for extended periods may affect device reliability and lifetime.

Note 2: Battery voltage must be adequate to drive gates of PowerPath P-channel FET switches. This does not affect charging voltage of the battery, which can be zero volts during wake-up charging.

Note 3: DCIN, BAT1, BAT2 are held at 12V and GDCl, GB11, GB21 are forced to 10.5V. SCP is set at 12V to measure source current at GDCl, GB11 and GB21. SCP is set at 11.9V to measure sink current at GDCl, GB11 and GB21.

Note 4: Extrapolated from testing with $C_L = 50\text{pF}$.

Note 5: Accuracy dependent upon external sense resistor and compensation components.

Note 6: The LTC1760 is tested under pulsed load conditions such that $T_J \approx T_A$. The LTC1760C is guaranteed to meet specifications from 0°C to 70°C junction temperature. Specifications over the -40°C to 85°C operating junction temperature range are assured by design, characterization and correlation with statistical process controls. The LTC1760I is guaranteed over the -40°C to 125°C operating junction temperature range.

Note 7: Charger servos to the value reported by a Voltage() query. This is the internal cell voltage measured by the battery electronics and may be

lower than the terminal voltage. Refer to "Operation Section 3.7" for more information.

Note 8: C_{LOAD} is the combined capacitance on the host's SMBus connection and the selected battery's SMBus connection.

Note 9: $C_{\text{LOAD_MAX}}$ is the maximum allowed combined capacitance on THxA, THxB and the battery's SafetySignalx connections.

Note 10: Does not include current supplied by V_{CC} to V_{CC2} ($I_{\text{VCC2_AC1}}$ or $I_{\text{VCC2_AC0}}$)

Note 11: Measured with thermistors not present, R_{VLIMIT} and R_{ILIMIT} removed and $\text{SMBALERT} = 1$. See Applications Information section: "Calculating IC Operating Current" for example on how to calculate total IC operating current.

Note 12: Requested currents below $44\text{mV}/R_{\text{SENSE}}$ may not servo correctly due to charger offsets. The charging current for requested currents below $4\text{mV}/R_{\text{SENSE}}$ will be between $4\text{mV}/R_{\text{SENSE}}$ and (Requested Current - 8mA). Refer to Applications Information: "Setting Charger Output Current Limit" for values of R_{SENSE} .

Note 13: This limit is greater than the absolute maximum for the charger. Therefore, there is no effective limitation for the voltage when this option is selected.

Note 14: Does not apply to Wake-Up Mode.

TYPICAL PERFORMANCE CHARACTERISTICS

Charging Voltage Accuracy

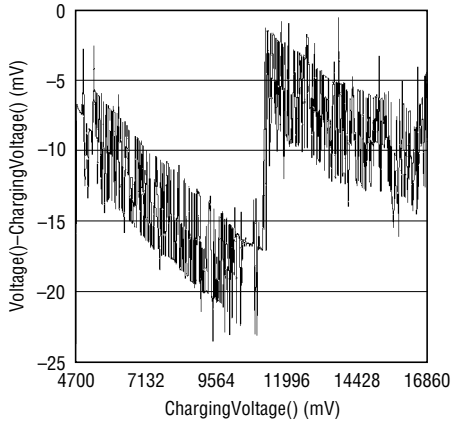

1760 G01

Charging Current Accuracy

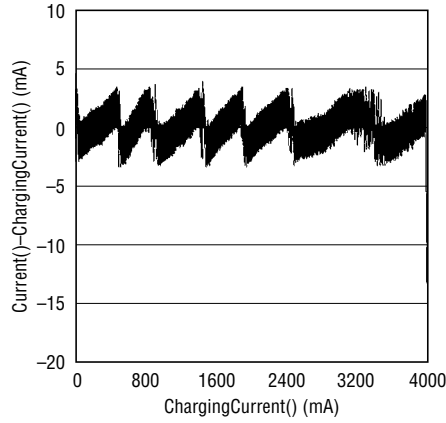

1760 G02

Dual Battery Charge Time vs Sequential Battery Charging

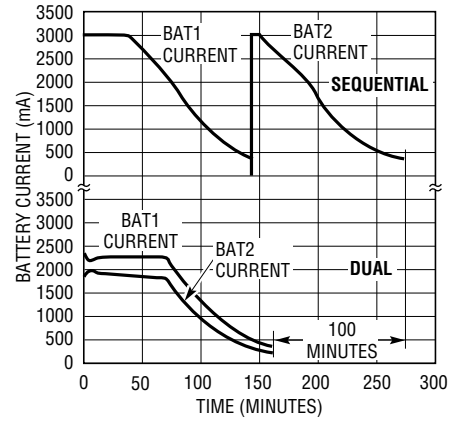

BATTERY TYPE: 10.8V Li-Ion (MOLTECH NI2020)
 REQUESTED CURRENT = 3A
 REQUESTED VOLTAGE = 12.3V
 MAX CHARGER CURRENT = 4.1A

1760 G03

Dual Charging Batteries with Different Charge State

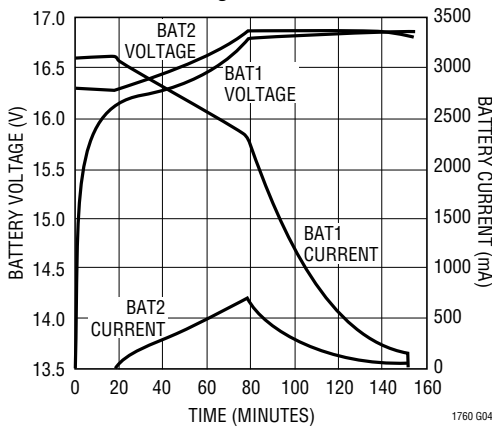

1760 G04

BAT1 INITIAL CAPACITY = 0%
 BAT2 INITIAL CAPACITY = 90%
 PROGRAMMED CHARGER CURRENT = 3A
 PROGRAMMED CHARGER VOLTAGE = 16.8V

Dual Battery Discharge Time vs Sequential Battery Discharge (Li-Ion)

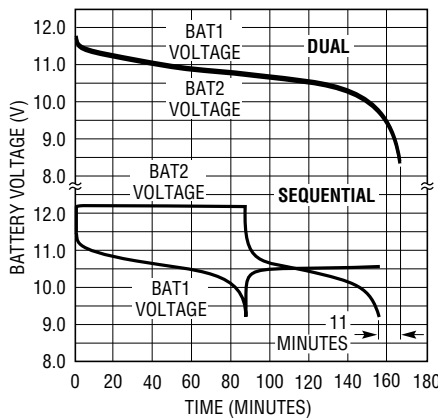

1760 G05

BATTERY TYPE: 10.8V Li-Ion (MOLTECH NI2020)
 LOAD CURRENT = 3A

Dual Battery Discharge Time vs Sequential Battery Discharge (NiMH)

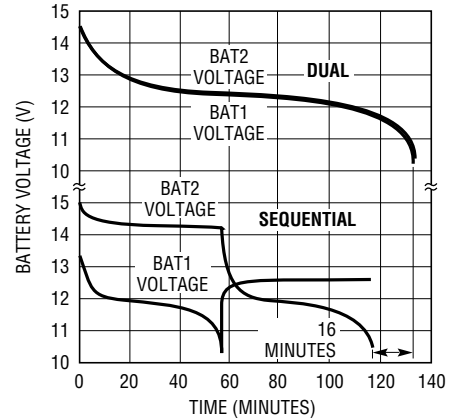

1760 G06

BATTERY TYPE: 12V NiMH (MOLTECH NJ1020)
 LOAD: 33W

TYPICAL PERFORMANCE CHARACTERISTICS

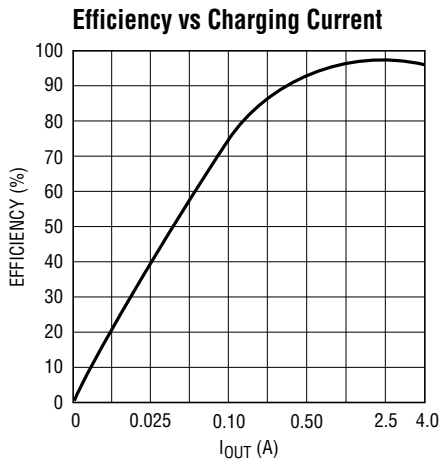

1760 G07

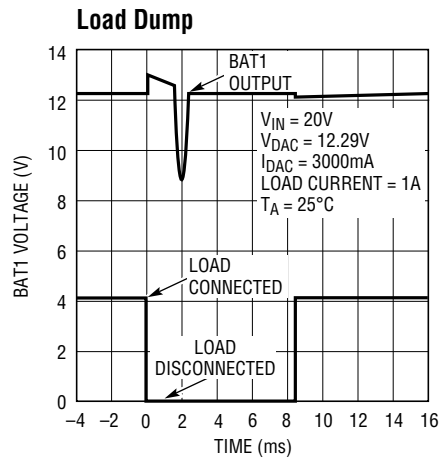

1760 G08

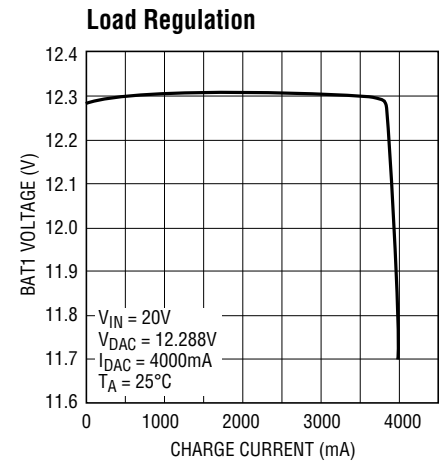

1760 G09

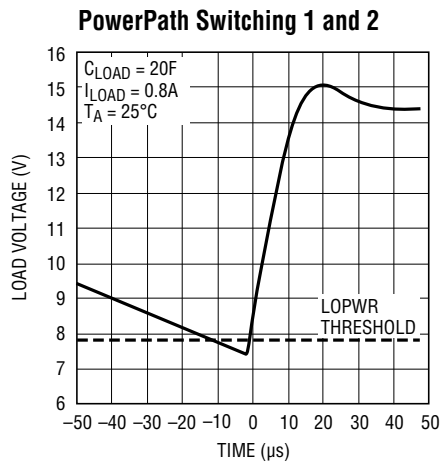

1960 G10

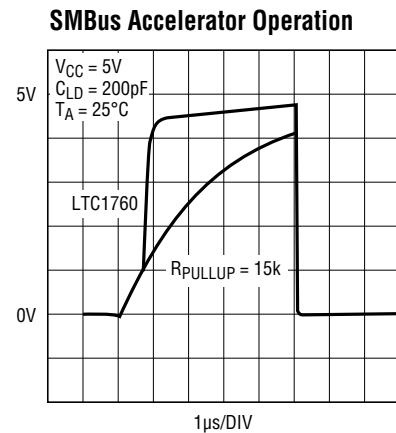

1760 G11

PIN FUNCTIONS

Input Power Related

SCN (Pin 4): PowerPath Current Sensing Negative Input. This pin should be connected directly to the “bottom” (output side) of the sense resistor, R_{SC} , in series with the three PowerPath switch pairs, for detecting short-circuit current events. Also powers the LTC1760 internal circuitry when all other sources are absent.

SCP (Pin 5): PowerPath Current Sensing Positive Input. This pin should be connected directly to the “top” (switch

side) of the sense resistor, R_{SC} , in series with the three PowerPath switch pairs, for detecting short-circuit current events.

GDCO (Pin 6): DCIN Output Switch Gate Drive. Together with GDCI, this pin drives the gate of the P-channel switch in series with the DCIN input switch.

GDCI (Pin 7): DCIN Input Switch Gate Drive. Together with GDCO, this pin drives the gate of the P-channel switch connected to the DCIN input.

PIN FUNCTIONS

GB10 (Pin 8): BAT1 Output Switch Gate Drive. Together with GB1I, this pin drives the gate of the P-channel switch in series with the BAT1 input switch.

GB11 (Pin 9): BAT1 Input Switch Gate Drive. Together with GB10, this pin drives the gate of the P-channel switch connected to the BAT1 input.

GB20 (Pin 10): BAT2 Output Switch Gate Drive. Together with GB2I, this pin drives the gate of the P-channel switch in series with the BAT2 input switch.

GB21 (Pin 11): BAT2 Input Switch Gate Drive. Together with GB20, this pin drives the gate of the P-channel switch connected to the BAT2 input.

CLP (Pin 36): The Positive Input to the Supply Current Limiting Amplifier CL1. The threshold is set at 100mV above the voltage at the DCIN pin. When used to limit supply current, a filter is needed to filter out the switching noise.

Battery Charging Related

V_{SET} (Pin 13): The Tap Point of a Programmable Resistor Divider which Provides Battery Voltage Feedback to the Charger. A capacitor from CSN to V_{SET} and from V_{SET} to GND provide necessary compensation and filtering for the voltage loop.

I_{TH} (Pin 14): The Control Signal of the Inner Loop of the Current Mode PWM. Higher I_{TH} voltage corresponds to higher charging current in normal operation. A capacitor of at least 0.1μF to GND filters out PWM ripple. Typical full-scale output current is 30μA. Nominal voltage range for this pin is 0V to 2.4V.

I_{SET} (Pin 15): A capacitor from I_{SET} to GND is required to filter higher frequency components from the delta-sigma I_{DAC}.

I_{LIMIT} (Pin 32): An external resistor (R_{I_{LIMIT}}) is connected between this pin and GND. The value of the external resistor programs the range and resolution of the programmed charger current.

V_{LIMIT} (Pin 33): An external resistor (R_{V_{LIMIT}}) is connected between this pin and GND. The value of the external resistor programs the range and resolution of the voltage DAC.

CSN (Pin 34): Current Amplifier CA1 Input. Connect this to the common output of the charger MUX switches.

CSP (Pin 35): Current Amplifier CA1 Input. This pin and the CSN pin measure the voltage across the charge current sense resistor, R_{SENSE}, to provide the instantaneous current signals required for both peak and average current mode operation.

COMP1 (Pin 37): The Compensation Node for the Amplifier CL1. A capacitor is required from this pin to GND if input current amplifier CL1 is used. At input adapter current limit, this node rises to 1V. By forcing COMP1 to GND, amplifier CL1 will be defeated (no adapter current limit). COMP1 can source 10μA.

BGATE (Pin 39): Drives the gate of the bottom external MOSFET of the battery charger buck converter.

SW (Pin 42): PWM Switch Node. Connected to the source of the top external MOSFET. Used as reference for top gate driver.

BOOST (Pin 43): Supply to Topside Floating Driver. The bootstrap capacitor is returned to this pin. Voltage swing at this pin is from a diode drop below V_{CC} to (DCIN + V_{CC}).

TGATE (Pin 44): Drives the gate of the top external MOSFET of the battery charger buck converter.

SCH1 (Pin 45), SCH2 (Pin 48): Charger MUX N-Channel Switch Source Returns. These two pins are connected to the sources of the back-to-back switch pairs Q3/Q4 and Q9/Q10 (see Typical Applications). A small pull-down current source returns these nodes to 0V when the switches are turned off.

GCH1 (Pin 46), GCH2 (Pin 47): Charger MUX N-Channel Switch Gate Drives. These two pins drive the gates of the back-to-back switch pairs, Q3/Q4 and Q9/Q10, between the charger output and the two batteries (see Typical Applications).

External Power Supply Pins

V_{PLUS} (Pin 1): Supply. The V_{PLUS} pin is connected via four internal diodes to the DCIN, SCN, BAT1, and BAT2 pins. Bypass this pin with a 0.1μF capacitor and a 1μF capacitor (see Typical Applications for complete circuit).

BAT1 (Pin 3), BAT2 (Pin 2): These two pins are the inputs from the two batteries for power to the LTC1760.

PIN FUNCTIONS

LOPWR (Pin 12): LOPWR Comparator Input from SCN External Resistor Divider to GND. If the voltage at LOPWR pin is lower than the LOPWR comparator threshold, then system power has failed and power is autonomously switched to a higher voltage source, if available.

DCDIV (Pin 16): External DC Source Comparator Input from DCIN External Resistor Divider to GND. If the voltage at DCDIV pin is above the DCDIV comparator threshold, then the AC_PRESENT bit is set and the wall adapter power is considered to be adequate to charge the batteries. If DCDIV rises more than 1.8V above V_{CC} , then all of the power path switches are latched off until all power is removed. A capacitor from DCDIV to GND is recommended to prevent noise-induced false emergency turn-off conditions from being detected. Refer to “Section 8.3” and “Typical Application”.

DCIN (Pin 41): Supply. External DC power source. A 0.1 μ F bypass capacitor must be connected to this pin as close as possible. No series resistance is allowed, since the adapter current limit comparator input is also this pin.

Internal Power Supply Pins

V_{DD5} (Pin 20): Power Supply for SMBus Accelerators. Also used in conjunction with MODE pin to modify the LTC1760 operating mode.

GND (Pin 24): Ground for Low Power Circuitry.

V_{CC2} (Pin 25): Power Supply is used Primarily to Power Internal Logic Circuitry. Must be connected to V_{CC} .

PGND (Pin 38): High Current Ground Return for BGATE Driver.

V_{CC} (Pin 40): Internal Regulator Output. Bypass this output with at least a 2 μ F to 4.7 μ F capacitor. Do not use this regulator output to supply external circuitry except as shown in the application circuit.

SBS Interface Pins

SCL2 (Pin 17): SMBus Clock Signal to Smart Battery 2. Do not connect to an external pull-up. The LTC1760 connects this pin to an internal pull-up (I_{PULLUP}) when required.

SCL (Pin 18): SMBus Clock Signal to SMBus Host. Also used to determine flashing rate for stand-alone charge indi-

cators. Requires an external pullup to V_{DD5} (normal SMBus operating mode). Connected to internal SMBus accelerator.

SCL1 (Pin 19): SMBus Clock Signal to Smart Battery 1. Do not connect to an external pull-up. The LTC1760 connects this pin to an internal pull-up (I_{PULLUP}) when required.

SDA2 (Pin 21): SMBus Data Signal to Smart Battery 2. Do not connect to an external pull-up. The LTC1760 connects this pin to an internal pull-up (I_{PULLUP}) when required.

SDA (Pin 22): SMBus Data Signal to SMBus Host. Also used to indicate charging status of Battery 2. Requires an external pullup to V_{DD5} . Connected to internal SMBus accelerator.

SDA1 (Pin 23): SMBus Data Signal to Smart Battery 1. Do not connect to an external pull-up. The LTC1760 connects this pin to an internal pull-up (I_{PULLUP}) when required.

MODE (Pin 26): Used in conjunction with V_{DD5} to allow SCL, SDA and $\overline{\text{SMBALERT}}$ to indicate charging status. May also be used as a hardware charge inhibit.

TH2B (Pin 27): Thermistor Force/Sense Connection to Smart Battery 2 SafetySignal. Connect to Battery 2 thermistor through resistor network shown in “Typical Application.”

TH2A (Pin 28): Thermistor Force/Sense Connection to Smart Battery 2 SafetySignal. Connect to Battery 2 thermistor through resistor network shown in “Typical Application.”

$\overline{\text{SMBALERT}}$ (Pin 29): Active Low Interrupt Pin. Signals SMBus Host that there has been a change of status in battery or AC presence. Open drain with weak current source pull-up to V_{CC2} (with Schottky to allow it to be pulled to 5V externally). Also used to indicate charging status of Battery 1.

TH1A (Pin 30): Thermistor Force/Sense Connection to Smart Battery 1 SafetySignal. Connect to Battery 1 thermistor through resistor network shown in “Typical Application.”

TH1B (Pin 31): Thermistor Force/Sense Connection to Smart Battery 1 SafetySignal. Connect to Battery 1 thermistor through resistor network shown in “Typical Application.”

BLOCK DIAGRAM

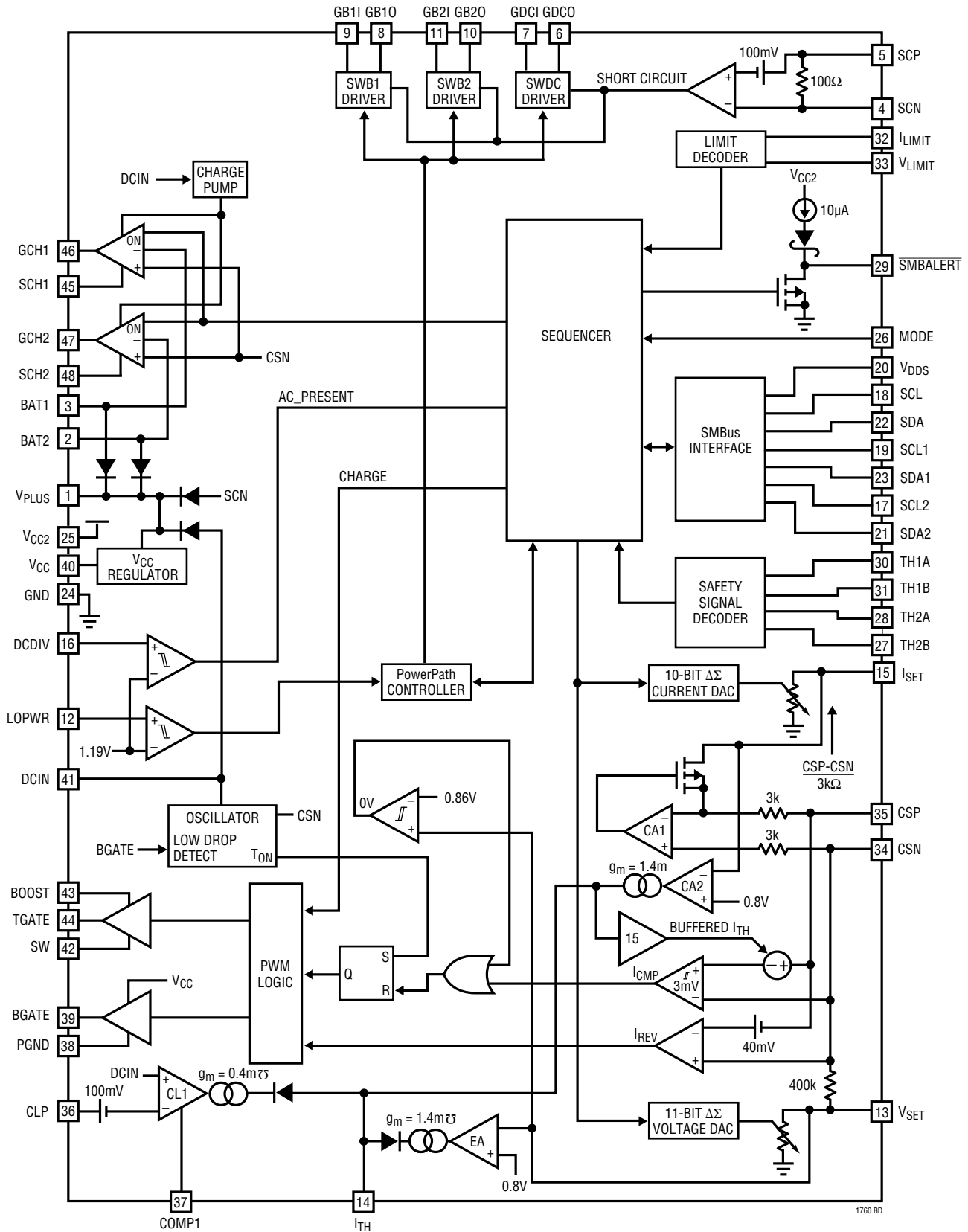

1760 BD

TABLE OF CONTENTS (For Operation Section)

1	Overview	14
2	The SMBus Interface.....	14
2.1	SMBus Interface Overview.....	14
2.3	Description of Supported SMBus Functions	17
2.3.1	BatterySystemState() (0x01)	17
2.3.2	BatterySystemStateCont() (0x02).....	18
2.3.3	BatterySystemInfo() (0x04).....	19
2.3.4	LTC() (0x3C)	20
2.3.5	BatteryMode() (0x03)	20
2.3.6	Voltage() (0x09).....	20
2.3.7	Current() (0x0A)	21
2.3.8	ChargingCurrent() (0x14)	21
2.3.9	ChargingVoltage() (0x15)	21
2.3.10	AlarmWarning() (0x16).....	21
2.3.11	AlertResponse()	22
2.4	SMBus Dual Port Operation	22
2.5	LTC1760 SMBus Controller Operation.....	23
2.6	LTC1760 SMBALERT Operation	26
3	Charging Algorithm Overview	26
3.1	Wake-Up Charging Initiation	26
3.2	Wake-Up Charging Termination	26
3.3	Wake-Up Charging Current and Voltage Limits.....	27
3.4	Controlled Charging Initiation	27
3.5	Controlled Charging Termination	27
3.6	Controlled Charging Current Programming	28
3.6.1	Current Limits When Charging A Single Battery.....	28
3.6.2	Current Limits When Charging Two Batteries (TURBO Mode Disabled)	28
3.6.3	Current Limits When Charging Two Batteries (TURBO Mode Enabled).....	29
3.7	Controlled Charging Voltage Programming.....	29
4	System Power Management Algorithm and Battery Calibration	29
4.1	Turning Off System Power	29
4.2	Power-By Algorithm When No Battery is Being Calibrated.....	29
4.3	Power-By Algorithm When a Battery is Being Calibrated.....	30
4.4	Power-By Reporting	30
5	Battery Calibration (Conditioning).....	30
5.1	Selecting a Battery to be Calibrated	30
5.2	Initiating Calibration of Selected Battery	31
5.3	Terminating Calibration of Selected Battery	31
6	MODE Pin Operation	31
6.1	Standalone Charge Indication	31
6.2	Hardware Charge Inhibit	32
6.3	Charging When SCL And SDA Are Low.....	32
6.4	Charging With an SMBus Host	32
7	Battery Charger Controller	32
7.1	Charge MUX Switches	33
7.2	Dual Charging	33
8	PowerPath Controller.....	33
8.1	Autonomous PowerPath Switching.....	34
8.2	Short-Circuit Protection	34
8.3	Emergency Turn-Off	34
8.4	Power-Up Strategy	34
9	The Voltage DAC Block	35
10	The Current DAC Block	35

OPERATION (Refer to Block Diagram and Typical Application Figure)

1 Overview

The LTC1760 is composed of an SMBus interface with dual port capability, a sequencer for managing system power and the charging and discharging of two batteries, a battery charger controller, charge MUX controller, PowerPath controller, a 10-bit current DAC (I_{DAC}) and 11-bit voltage DAC (V_{DAC}). When coupled with optional system software for generating composite battery information, it forms a complete Smart Battery System Manager for charging and selecting two smart batteries. The battery charger is controlled by the sequencer which uses a Level 3 SMBus interface to read `ChargingVoltage()`, `Voltage()`, `ChargingCurrent()`, `Current()`, `Alarm()` and `BatteryMode()`. This information, together with thermistor measurements allows the sequencer to select the charging battery and safely servo on voltage and current. Charging can be accomplished only if the voltage at DCDIV indicates that sufficient voltage is available from the input power source, usually an AC adapter. The charge MUX, which selects the battery to be charged, is capable of charging both batteries simultaneously. The charge MUX switch drivers are configured to allow charger current to share between the two batteries and to prevent current from flowing in a reverse direction in the switch. The amount of current that each battery receives will depend upon the relative capacity of each battery and the battery voltage. This can result in significantly shorter charging times (up to 50% for Li-Ion batteries) than sequential charging of each battery.

The sequencer also selects which of the pairs of PFET switches will provide power to the system load. If the system voltage drops below the threshold set by the LOPWR resistor divider, then all of the output-side PFETs are turned on quickly. The input-side PFETs act as diodes in this mode and power is taken from the highest voltage source available at the DCIN, BAT1, or BAT2 inputs. The input-side PowerPath switch driver that is delivering power then closes its input switch to reduce the power dissipation in the PFET bulk diode. In effect, this system provides

diode-like behavior from the FET switches, without the attendant high power dissipation from diodes. The Host is informed of this 3-Diode mode status when it polls the PowerPath status register via the SMBus interface. High speed PowerPath switching at the LOPWR trip point is handled autonomously.

Simultaneous discharge of both batteries is supported. The switch drivers prevent reverse current flow in the switches and automatically discharge both batteries into the load, sharing current according to the relative capacity of the batteries. Simultaneous dual discharge can increase battery operating time by up to 10% by reducing losses in the switches and reducing internal battery losses associated with high discharge rates.

2 The SMBus Interface

2.1 SMBus Interface Overview

The SMBus interface allows the LTC1760 to communicate with two batteries and the SMBus Host. The SMBus Interface supports true dual port operation by allowing the SMBus Host to be connected to the SMBus of either battery. The LTC1760 is able to operate as an SMBus Master or Slave device. The LTC1760 SMBUS address is 0x14 (8-bit format).

References:

Smart Battery System Manager Specification: Revision 1.1, SBS Implementers Forum.

Smart Battery Data Specification: Revision 1.1, SBS Implementers Forum.

Smart Battery Charger Specification: Revision 1.1, SBS Implementers Forum

System Management Bus Specification: Revision 1.1, SBS Implementers Forum

I²C-Bus and How to Use it: V1.0, Philips Semiconductor.

OPERATION

2.2 Data Bit Definition of Supported SMBus Functions.

Function	LTC1760 SMBus Mode	Access	SMBus Address	Command Code	Data Type	Data Bit or Nibble Definition/Allowed Values (See section 2.3 for Details)																
						D15	D14	D13	D12	D11	D10	D09	D08	D07	D06	D05	D04	D03	D02	D01	D00	
BatterySystemState()	Slave	Read/Write	7-bit: 0001_010b 8-bit: 0x14	0x01	Status/Control	SMB_BAT4	SMB_BAT3	SMB_BAT2	SMB_BAT1	POWER_BY_BAT4	POWER_BY_BAT3	POWER_BY_BAT2	POWER_BY_BAT1	CHARGE_BAT4	CHARGE_BAT3	CHARGE_BAT2	CHARGE_BAT1	PRESENT_BAT4	PRESENT_BAT3	PRESENT_BAT2	PRESENT_BAT1	
						0	0	0/1	0/1	0	0	0/1	0/1	0	0	0/1	0/1	0	0	0/1	0/1	
BatterySystemStateCont()	Slave	Read/Write	7-bit: 0001_010b 8-bit: 0x14	0x02	Status/Control	RESERVED	RESERVED	RESERVED	RESERVED	CALIBRATE_BAT4	CALIBRATE_BAT3	CALIBRATE_BAT2	CALIBRATE_BAT1	RESERVED	CALIBRATE	CHARGER_POR	CHARGING_INHIBIT	CALIBRATE_REQUEST	CALIBRATE_REQUEST_SUPPORT	POWER_NOT_GOOD	AC_PRESENT	
						0	0	0	0	0	0	0/1	0/1	0	0/1	0/1	0/1	0/1	1	0/1	0/1	
BatterySystemInfo()	Slave	Read	7-bit: 0001_010b 8-bit: 0x14	0x04	Status	RESERVED	RESERVED	RESERVED	RESERVED	RESERVED	RESERVED	RESERVED	RESERVED	BATTERY SYSTEM REVISION	BATTERY SYSTEM REVISION	BATTERY SYSTEM REVISION	BATTERY SYSTEM REVISION	BATTERY SUPPORTED	BATTERY SUPPORTED	BATTERY SUPPORTED	BATTERY SUPPORTED	
						0	0	0	0	0	0	0	0	1	0	0	0	0	0	0	1	1
LTC()	Slave	Read/Write	7-bit: 0001_010b 8-bit: 0x14	0x3C	Status/Control	POWER_OFF	RESERVED	RESERVED	RESERVED	RESERVED	RESERVED	RESERVED	RESERVED	TURBO	RESERVED	RESERVED	RESERVED	LTC_VERSION3	LTC_VERSION2	LTC_VERSION1	LTC_VERSION0	
						0/1	0	0	0	0	0	0	1	0/1	0	0	0	0	0	0	1	
BatteryMode()	Master	Read	7-bit: 0001_011b 8-bit: 0x16	0x03	Status	RESERVED	RESERVED	RESERVED	RESERVED	RESERVED	RESERVED	RESERVED	RESERVED	CONDITION_FLAG	RESERVED	RESERVED	RESERVED	RESERVED	RESERVED	RESERVED	RESERVED	
						0/1	0/1	0/1	0/1	0/1	0/1	0/1	0/1	0/1	0/1	0/1	0/1	0/1	0/1	0/1	0/1	

OPERATION

Function	LTC1760 Mode	Access	SMBus Address	Command Code	Data Type	Data Bit or Nibble Definition/Allowed Values (See section 2.3 for Details)															
						D15	D14	D13	D12	D11	D10	D09	D08	D07	D06	D05	D04	D03	D02	D01	D00
Current()	Master	Read	7-bit: 0001_011b 8-bit: 0x16	0x0A	Value	IA15	IA14	IA13	IA12	IA11	IA10	IA09	IA08	IA07	IA06	IA05	IA04	IA03	IA02	IA01	IA00
						0/1	0/1	0/1	0/1	0/1	0/1	0/1	0/1	0/1	0/1	0/1	0/1	0/1	0/1	0/1	0/1
Voltage()	Master	Read	7-bit: 0001_011b 8-bit: 0x16	0x09	Status/ Control	VA15	VA14	VA13	VA12	VA11	VA10	VA09	VA08	VA07	VA06	VA05	VA04	VA03	VA02	VA01	VA00
						0/1	0/1	0/1	0/1	0/1	0/1	0/1	0/1	0/1	0/1	0/1	0/1	0/1	0/1	0/1	0/1
ChargingCurrent()	Master	Read	7-bit: 0001_011b 8-bit: 0x16	0x14	Status	IR15	IR14	IR13	IR12	IR11	IR10	IR09	IR08	IR07	IR06	IR05	IR04	IR03	IR02	IR01	IR00
						0/1	0/1	0/1	0/1	0/1	0/1	0/1	0/1	0/1	0/1	0/1	0/1	0/1	0/1	0/1	0/1
ChargingVoltage()	Master	Read	7-bit: 0001_011b 8-bit: 0x16	0x15	Status/ Control	VR15	VR14	VR13	VR12	VR11	VR10	VR09	VR08	VR07	VR06	VR05	VR04	VR03	VR02	VR01	VR00
						0/1	0/1	0/1	0/1	0/1	0/1	0/1	0/1	0/1	0/1	0/1	0/1	0/1	0/1	0/1	0/1
AlarmWarning()	Master	Read	7-bit: 0001_010b 8-bit: 0x16	0x16	Status	OVER_CHARGED	TERMINATE_CHARGE_ALARM	TERMINATE_CHARGE_RESERVED	OVER_TEMP_ALARM	TERMINATE_DISCHARGE_ALARM	RESERVED	RESERVED	RESERVED	RESERVED	RESERVED	RESERVED	FULLY_DISCHARGED	RESERVED	RESERVED	RESERVED	RESERVED
						0/1	0/1	0/1	0/1	0/1	0/1	0/1	0/1	0/1	0/1	0/1	0/1	0/1	0/1	0/1	0/1
AlertResponse() see (1)	Slave	Read Byte	7-bit: 0001_100b 8-bit: 0x18	N/A	Register									ARA_ADD07	ARA_ADD06	ARA_ADD05	ARA_ADD04	ARA_ADD03	ARA_ADD02	ARA_ADD01	ARA_ADD00
																		0	0	0	1

(1) Read-byte format. 0x14 is returned as the interrupt address of the LTC1760.

OPERATION

2.3 Description of Supported SMBus Functions

The functions are described as follows:

Function Name() (command code)

Description:

A brief description of the function.

Purpose:

The purpose of the function, and an example where appropriate.

SMBus Protocol: Refer to Section 2.5 and to the SMBus specification for more details.

Input, Output or Input/Output: A description of the data supplied to, or returned by, the function.

Whenever the LTC1760 encounters a valid command with invalid data, it ACKs the command, and ignores the invalid data. For example, if an attempt is made to select Battery 1 and 2 to simultaneously communicate with the system host, the LTC1760 will just ignore the request.

2.3.1 BatterySystemState() (0x01)

Description:

This function returns the present state of the LTC1760 and allows access to individual batteries. The information is broken into four nibbles that report:

- Which battery is communicating with the SMBus Host
- Which batteries, if any, or AC is powering the system
- Which batteries are connected to the Smart Charger
- Which batteries are present.

The LTC1760 provides a mechanism to notify the system whenever there is a change in its state. Specifically, the LTC1760 provides the system with a notification whenever:

- A battery is added or removed (Polling or $\overline{\text{SMBALERT}}$).
- AC power is connected or disconnected (Polling or $\overline{\text{SMBALERT}}$).
- The LTC1760 autonomously changes the configuration of the batteries supplying power (Polling only).

- The LTC1760 autonomously changes the configuration of the batteries being charged (Polling only).

Purpose:

Used by the SMBus Host to determine the present state of the LTC1760 and the attached batteries. It also may be used to determine the state of the battery system after the LTC1760 notifies the SMBus Host of a change via $\overline{\text{SMBALERT}}$.

SMBus Protocol: Read or Write Word.

Input/Output: word – Refer to “Section 2.2” for bit mapping.

SMB_BAT[4:1] Nibble

The read/write SMB_BAT[4:1] nibble is used by the SMBus Host to select with which individual battery to communicate or to determine with which individual battery it is communicating.

For example, an application that displays the remaining capacity of all batteries would write to this nibble to individually select each battery in turn and get its capacity.

Allowed values are:

- 0010b: SMBus Host is communicating with Battery 2.
- 0001b: SMBus Host is communicating with Battery 1. (Power On Reset Value)

To change this nibble, set only one of the lower two bits of this nibble high. All other values will simply be ignored.

POWER_BY_BAT[4:1] Nibble

The read only POWER_BY_BAT[4:1] nibble is used by the SMBus Host to determine which batteries are powering the system. All writes to this nibble will be ignored.

Allowed values are:

- 0011b: System powered by both Battery 2 and Battery 1 simultaneously.
- 0010b: System powered by Battery 2 only.
- 0001b: System powered by Battery 1 only.
- 0000b: System powered by AC adapter only.

OPERATION

CHARGE_BAT[4:1] Nibble

The read only CHARGE_BAT[4:1] nibble is used by the SMBus Host to determine which, if any, battery is being charged. All writes to this nibble will be ignored.

Allowed values are:

0011b: Both Battery 2 and Battery 1 being charged.

0010b: Only Battery 2 is being charged.

0001b: Only Battery 1 is being charged.

0000b: No battery being charged.

An indication that multiple batteries are being charged simultaneously does not indicate that the batteries are being charged at the same rate or that they will complete their charge at the same time. To actually determine when an individual battery will be fully charged, use the SMB_BAT[4:1] nibble to individually select the battery of interest and read the TimeToFull() value.

PRESENT_BAT[4:1] Nibble

The read only PRESENT_BAT[4:1] nibble is used by the SMBus Host to determine how many and which batteries are present. All writes to this nibble will be ignored.

Allowed values are:

0011b: Both Battery 2 and Battery 1 are present.

0010b: Only Battery 2 is present.

0001b: Only Battery 1 is present.

0000b: No batteries are present.

2.3.2 BatterySystemStateCont() (0x02)

Description:

This function returns additional state information of the LTC1760 and provides a mechanism to prohibit charging. This command also removes any requirement for the SMBus Host to communicate directly with the charger to obtain AC presence information. When the LTC1760 is used, access to the charger 8-bit address, 0x012, is blocked.

Purpose:

Used by the SMBus Host to retrieve additional state information from the LTC1760 and the overall system

power configuration. It may also be used by the system to prohibit any battery charging.

SMBus Protocol: Read or Write Word.

Input/Output: word - Refer to “Section 2.2” for bit mapping

AC_PRESENT Bit

The read only AC_PRESENT bit is used to show the user the status of AC availability to power the system. It may be used internally by the SMBus Host in conjunction with other information to determine when it is appropriate to allow a battery conditioning cycle. Whenever there is a change in the AC status, the LTC1760 asserts SMBALERT low. In response, the system has to read this register to determine the actual presence of AC. The LTC1760 uses the DCDIV pin to measure the presence of AC.

Allowed values are:

1b: The LTC1760 has determined that AC is present.

0b: The LTC1760 has determined that AC is not present.

POWER_NOT_GOOD Bit

The read only POWER_NOT_GOOD bit is used to show that the voltage delivered to the system load is inadequate. This is determined by the LOPWR comparator.

The POWER_NOT_GOOD bit will also be set if the LTC1760 has detected a short circuit condition (see “Section 8.2”) or an emergency turn-off condition (see “Section 8.3”). Under either of these conditions the power paths will be shut off even if battery or DC power is available.

Allowed values are:

1b: The LTC1760 has determined that the voltage delivered to the system load is inadequate.

0b: The LTC1760 has determined that the voltage delivered to the system load is adequate.

CALIBRATE_REQUEST_SUPPORT Bit

The read only CALIBRATE_REQUEST_SUPPORT bit is always set high to indicate that the LTC1760 has a mechanism to determine when any of the attached batteries are in need of a calibration cycle.

OPERATION

CALIBRATE_REQUEST Bit

The read only CALIBRATE_REQUEST bit is set whenever the LTC1760 has determined that one or both of the connected batteries need a calibration cycle.

Allowed values are:

- 1b: The LTC1760 has determined that one or both batteries requires calibration.
- 0b: The LTC1760 has determined that neither battery require calibration.

CHARGING_INHIBIT Bit

The read/write CHARGING_INHIBIT bit is used by the SMBus Host to inhibit charging or to determine if charging is inhibited. This bit is also set if the MODE pin is used to inhibit charging.

Allowed values are:

- 1b: The LTC1760 will not allow any battery charging to occur.
- 0b: The LTC1760 may charge batteries as needed, (Power On Reset Value).

CHARGER_POR Bit

The read/write CHARGER_POR bit is used to force a charger power on reset.

Writing a 1 to this bit will cause a charger power on reset with the following effects.

- Charging will be turned off and wake-up charging will be resumed. This is the same as if the batteries were removed and then reinserted.
- The three minute wake-up watchdog timer will be restarted.

Writing a 0 to this bit has no effect. A read of this bit always returns a 0.

CALIBRATE Bit

The read/write CALIBRATE bit is used either to show the status of battery calibration cycles in the LTC1760 or to begin or end a calibration cycle.

CALIBRATE_BAT[4:1] Nibble

The read/write CALIBRATE_BAT[4:1] nibble is used by the SMBus Host to select the battery to be calibrated or to determine which individual battery is being calibrated.

Allowed read values are:

- 0010b: Battery 2 is being calibrated. CALIBRATE must be 1.
- 0001b: Battery 1 is being calibrated. CALIBRATE must be 1.
- 0000b: No batteries are being calibrated.

Allowed write values are:

- 0010b: Select Battery 2 for calibration.
- 0001b: Select Battery 1 for calibration.
- 0000b: Allow LTC1760 to choose battery to be calibrated.

All other values will simply be ignored. This provides a mechanism to update the other BatterySystemStateCont() bits without altering this nibble.

2.3.3 BatterySystemInfo() (0x04)

Description:

The SMBus Host uses this function to determine the capabilities of the LTC1760.

Purpose:

Allows the SMBus Host to determine the number of batteries the LTC1760 supports as well as the specification revision implemented by the LTC1760.

SMBus Protocol: Read Word

Input/Output: word — Refer to “Section 2.2” for bit mapping.

BATTERIES_SUPPORTED Nibble

The read only BATTERIES_SUPPORTED nibble is used by the SMBus Host to determine how many batteries the LTC1760 can support. The two-battery LTC1760 always returns 0011b for this nibble.

OPERATION

BATTERY_SYSTEM_REVISION Nibble

The read only BATTERY_SYSTEM_REVISION nibble reports the version of the Smart Battery System Manager specification supported.

LTC1760 always returns 1000b for this nibble, indicating Version 1.0 without optional PEC support.

2.3.4 LTC() (0×3C)

Description:

This function returns the LTC version nibble and allows the user to perform expanded Smart Battery System Manager functions.

Purpose:

Used by the SMBus Host to determine the version of the LTC1760 and to program and monitor TURBO and POWER_OFF special functions.

SMBus Protocol: Read or Write Word.

Input/Output: word — Refer to “Section 2.2” for bit mapping.

POWER_OFF Bit

This read/write bit allows the LTC1760 to turn off all power paths.

Allowed values:

1b: All power paths are off.

0b: All power paths are enabled. (power on reset value).

TURBO Bit

This read/write bit allows the LTC1760 to enter TURBO charging mode. Refer to “section 3.6”.

Allowed values:

1b: Turbo charging mode enabled.

0b: Turbo charging mode disabled. (Power On Reset Value).

LTC_Version[3:0] Nibble

This read only nibble always returns 0001b as the LTC1760 version.

2.3.5 BatteryMode() (0×03)

Description:

This function is used by the LTC1760 to read the battery’s Mode register.

Purpose:

Allows the LTC1760 to determine if a battery requires a conditioning/calibration cycle.

SMBus Protocol: Read Word. LTC1760 reads Battery 1 or Battery 2 as an SMBus Master.

Input/Output: word — Refer to “Section 2.2” for bit mapping.

CONDITION_FLAG Bit

The CONDITION_FLAG bit is set whenever the battery requires calibration.

Allowed values:

1b: Battery requires calibration. (Also known as a Condition Cycle Request).

0b: Battery does not require calibration.

2.3.6 Voltage() (0×09)

Description:

This function is used by the LTC1760 to read the actual cell-pack voltage .

Purpose:

Allows the LTC1760 to determine the cell pack voltage and close the charging voltage servo loop.

SMBus Protocol: Read Word. LTC1760 reads Battery 1 or Battery 2 as an SMBus Master.

Output: unsigned integer — battery terminal voltage in milli-volts. Refer to “Section 2.2” for bit mapping.

Units: mV.

Range: 0 to 65,535 mV.

OPERATION

2.3.7 Current() (0×0A)

Description:

This function is used by the LTC1760 to read the actual current being supplied through the battery terminals.

Purpose:

Allows the LTC1760 to determine how much current a battery is receiving through its terminals and close the charging current servo loop.

SMBus Protocol: Read Word. LTC1760 reads Battery 1 or Battery 2 as an SMBus Master.

Output: signed integer (2's complement) — charge/discharge rate in mA increments - positive for charge, negative for discharge. Refer to "Section 2.2" for bit mapping.

Units: mA.

Range: 0 to 32,767 mA for charge or 0 to -32,768 mA for discharge.

2.3.8 ChargingCurrent() (0×14)

Description:

This function is used by the LTC1760 to read the Smart Battery's desired charging current.

Purpose:

Allows the LTC1760 to determine the maximum charging current.

SMBus Protocol: Read Word. LTC1760 reads Battery 1 or Battery 2 as an SMBus Master.

Output: unsigned integer — maximum charger output current in mA. Refer to "Section 2.2" for bit mapping.

Units: mA.

Range: 0 to 65,534 mA.

2.3.9 ChargingVoltage() (0×15)

Description:

This function is used by the LTC1760 to read the Smart Battery's desired charging voltage.

Purpose:

Allows the LTC1760 to determine the maximum charging voltage.

SMBus Protocol: Read Word. LTC1760 reads Battery 1 or Battery 2 as an SMBus Master.

Output: unsigned integer — charger output voltage in mV. Refer to "Section 2.2" for bit mapping.

Units: mV.

Range: 0 to 65,534 mV.

2.3.10 AlarmWarning() (0×16)

Description:

This function is used by the LTC1760 to read the Smart Battery's Alarm register.

Purpose:

Allows the LTC1760 to determine the state of all applicable alarm flags.

SMBus Protocol: Read Word. LTC1760 reads Battery 1 or Battery 2 as an SMBus Master.

Output: unsigned integer – Refer to "Section 2.2" for bit mapping.

OVER_CHARGED_ALARM Bit

The read only OVER_CHARGED_ALARM bit is used by the LTC1760 to determine if charging may continue.

Allowed values are:

- 1b: The LTC1760 will not charge this battery.
- 0b: The LTC1760 may charge this battery if other conditions permit charging.

TERMINATE_CHARGE_ALARM Bit

The read only TERMINATE_CHARGE_ALARM bit is used by the LTC1760 to determine if charging may continue.

Allowed values are:

- 1b: The LTC1760 will not charge this battery.
- 0b: The LTC1760 may charge this battery if other conditions permit charging.

OPERATION

TERMINATE_CHARGE_RESERVED Bit

The read only TERMINATE_CHARGE_RESERVED bit is used by the LTC1760 to determine if charging may continue.

Allowed values are:

- 1b: The LTC1760 will not charge this battery.
- 0b: The LTC1760 may charge this battery if other conditions permit charging.

OVER_TEMP_ALARM Bit

The read only OVER_TEMP_ALARM bit is used by the LTC1760 to determine if charging may continue.

Allowed values are:

- 1b: The LTC1760 will not charge this battery.
- 0b: The LTC1760 may charge this battery if other conditions permit charging.

TERMINATE_DISCHARGE_ALARM Bit

The read only TERMINATE_DISCHARGE_ALARM bit is used by the LTC1760 to determine if discharge from the battery is still allowed. This is used for PowerPath management and battery calibration.

Allowed values are:

- 1b: The LTC1760 will terminate calibration and should try to not use this battery in the power path. When all other power paths fail the LTC1760 will ignore this alarm and still try to supply system power from this battery.
- 0b: The LTC1760 may continue discharging this battery.

FULLY_DISCHARGED Bit

The read only FULLY_DISCHARGED bit is used by the LTC1760 to determine if discharge from the battery is still allowed. This is used for PowerPath management and battery calibration.

Allowed values are:

- 1b: The LTC1760 will terminate calibration and should try to not use this battery in the power path. When all other power paths fail the LTC1760 will ignore this alarm and still try to supply system power from this battery.
- 0b: The LTC1760 may continue discharging this battery.

2.3.11 AlertResponse()

Description:

The SMBus Host uses the Alert Response Address (ARA) to simultaneously address all devices on the SMBus and determine which devices are currently asserting $\overline{\text{SMBALERT}}$.

Purpose:

This command allows the SMBus Host to identify the subset of devices that have new status data. This reduces the number of reads required to refresh all status information from the system. The SMBus Host begins an ARA by transmitting the 8-bit address, 0x18, to all devices. ARA-compliant devices that are asserting $\overline{\text{SMBALERT}}$ will then simultaneously return their address on the next read byte. While transmitting their address each device monitors SDA. If a lower address is present, the device transmitting the higher address will see that SDA does not match and it will stop transmitting its address. When a device sees its full address has been received it will stop asserting $\overline{\text{SMBALERT}}$ and the Host will know to read status from this device. Subsequent ARA requests will allow the Host to complete the list of devices requiring servicing.

Output:

The LTC1760 will transmit its 8-bit address, 0x14, in response to an ARA request. The LTC1760 will stop transmitting its address if another device with a lower address is also responding to the ARA. The LTC1760 will de-assert $\overline{\text{SMBALERT}}$ when it successfully returns its address.

The following events will cause the LTC1760 to pull-down the $\overline{\text{SMBALERT}}\#$ bus through the $\overline{\text{SMBALERT}}$ pin:

- Change of AC_PRESENT in the BatterySystemStateCont() function.
- Change of BATTERY_PRESENT in the BatterySystemState() function.
- Internal power on reset condition.

Refer to "Section 2.2" for bit mapping.

2.4 SMBus Dual Port Operation

The SMBus Interface includes the LTC1760's SMBus controller, as well as circuitry to arbitrate and connect the battery and SMBus Host interfaces. The SMBus controller generates and interprets all LTC1760 SMBus functions.

OPERATION

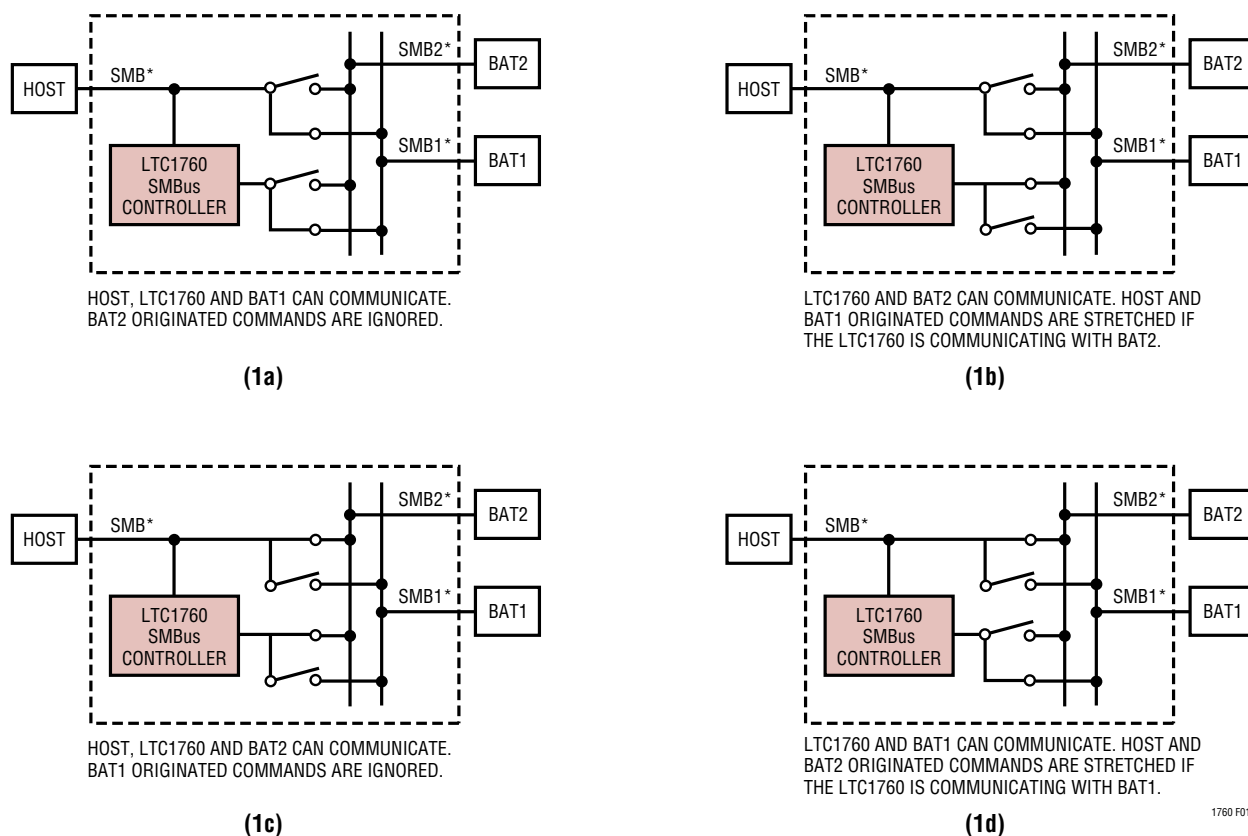

*SMB INCLUDES SCL AND SDA, SMB1 INCLUDES SCL1 AND SDA1, AND SMB2 INCLUDES SCL2 AND SDA2.

Figure 1. Switch Configurations Used by the LTC1760 for Managing Dual Port Battery Communication

The dual port operation allows the SMBus Host to be connected to the SMBus of either battery by setting the SMB_BAT[4:1] nibble. Arbitration is handled by stretching an SMBus start sequence when a bus collision might occur. Whenever configurations are switched, the LTC1760 will generate a harmless SMBus reset on SMB1 and SMB2 as required. The four possible configurations are illustrated in Figure 1. Sample SMBus communications are shown in Figures 2 and 3.

2.5 LTC1760 SMBus Controller Operation

SMBus communication with the LTC1760 is handled by the SMBus Controller, a sub-block of the SMBus Interface. Data is clocked into the SMBus Controller block shift register after the rising SCL edge. Data is clocked out of the SMBus Control block shift register after the falling edge of SCL.

The LTC1760 acting as a Slave will acknowledge (ACK) each byte of serial data. The Command byte will be NACKed if

an invalid command code is transmitted to the LTC1760. The SMBus Controller must respond if addressed as a combined Smart Battery System Manager at 8-bit address 0x14. A valid address includes a legal Read/Write bit. The SMBus Controller will ignore invalid data although the data transmission with the invalid data will still be ACKed.

When the LTC1760, acting as a bus Master receives a NACK, it will terminate the transmission and provide a STOP condition on the bus.

Detection of a STOP condition, power on reset, or SMBus time out will reset the Controller to an initial state at any time.

The LTC1760 supports ARA, Write Word and Read Word protocols as an SMBus Slave. The LTC1760 supports Read Word protocol as an SMBus Master.

Refer to “System Management Bus Specification” for a complete description of required operation and symbols.

1760fc

OPERATION

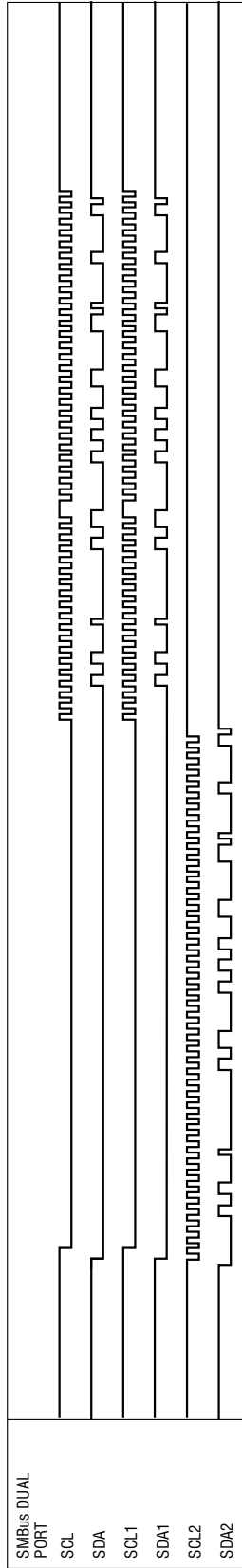

Figure 2. LTC1760 Stretches Host's Communication With Battery 1 While It Completes a Read Of Battery 2. (Configuration b)

OPERATION

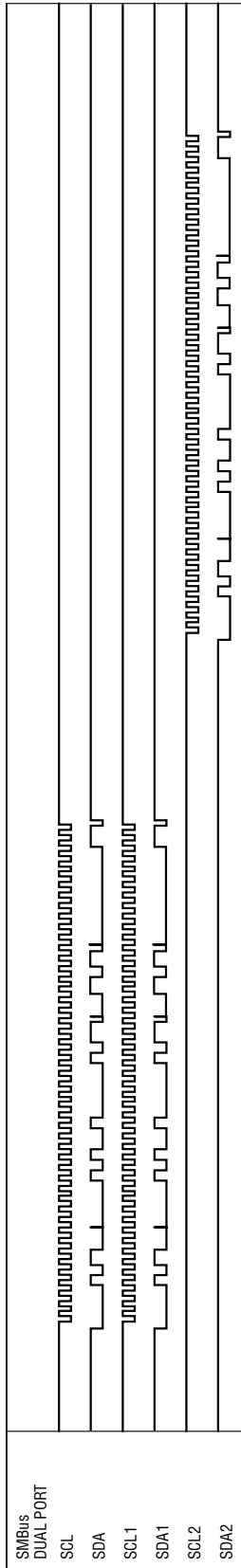

Figure 3. LTC1760 Queries Battery 1 Followed By Battery 2 For Requested Current. (Configuration b)

OPERATION

2.6 LTC1760 SMBALERT Operation

The `SMBALERT` pin allows the LTC1760 to signal to the SMBus Host that there has been a change of status.

This pin is asserted low whenever there is a change in battery presence, AC presence or after a power on reset event. This pin is cleared during an Alert Response or any of the following reads:

`BatterySystemState()`, `BatterySystemStateCont()`, `BatterySystemInfo()`, or `LTC()`.

3 Charging Algorithm Overview

3.1 Wake-Up Charging Initiation

The following conditions must be met in order to allow wake-up charging:

1. The battery thermistor must be COLD-RANGE, IDEAL-RANGE, or UNDER-RANGE.
2. AC must be present.
3. `BatterySystemStateCont(CHARGING_INHIBIT)` must be de-asserted (or low).
4. Hardware controlled charging inhibit must be de-asserted (MODE not low with V_{DD5} high). Refer to "Section 6.2".

Wake-up charging initiates when a newly inserted battery does not respond to any LTC1760 Master read commands. Only one battery will wake-up charge at a time. When two batteries are inserted and both require wake-up charging, Battery 1 will wake-up charge first. Battery 2 will only wake-up charge when Battery 1 terminates wake-up charging.

Wake-up charging takes priority over controlled charging; this prevents one battery from tying up the charger when it would be advantageous to dual charge two deeply discharged batteries.

The LTC1760 will attempt to reinitiate wake-up charging on both batteries after the SMBus Host asserts `BatterySystemStateCont(CHARGER_POR)` or a power on reset event. This will reset any wake-up charging safety timers and is equivalent to removing and reinserting both batteries.

The LTC1760 will attempt to reinitiate wake-up charging on a battery if the battery is not being charged, the thermistor is reporting IDEAL-RANGE, and the battery fails to respond to an SMBus query. This is an important feature for handling deeply discharged NiMH batteries. These batteries may begin to talk while being charged and go silent once charging has stopped.

Wake-up charging is disabled if the battery thermistor is COLD-RANGE or UNDER-RANGE and the battery has been charged for longer than $t_{TIMEOUT}$.

3.2 Wake-Up Charging Termination

The LTC1760 will terminate wake-up charging when any of the following conditions are met:

1. Battery removal (thermistor indicating OVER-RANGE)
2. AC is removed.
3. The SMBus Host issues a calibration request by setting `BatterySystemStateCont(CALIBRATE)` high.
4. Any response to an LTC1760 Master read of `ChargingCurrent()`, `Current()`, `ChargingVoltage()`, or `Voltage()`. Note that the LTC1760 ignores all writes from the battery.
5. Any of the following `AlarmWarning()` bits asserted high:

`OVER_CHARGED_ALARM`
`TERMINATE_CHARGE_ALARM`
`TERMINATE_CHARGE_RESERVED`
`OVER_TEMP_ALARM`

Note that the LTC1760 ignores all writes from the battery. Each battery's charge alarm is cached inside the LTC1760. This internally cached bit will be set when any of the upper four bits of the battery's `AlarmWarning()` response are set. The cached bit will remain set if a subsequent `AlarmWarning()` fails to respond. The cached alarm will be cleared by any of the following conditions.

- a) Associated battery is removed.
- b) A subsequent `AlarmWarning()` clears all charge alarm bits for the associated battery.
- c) A power on reset event.

OPERATION

- d) The SMBus Host asserts BatterySystemStateCont(CHARGER_POR) high.
- 6. The SMBus Host asserts BatterySystemStateCont(CHARGING_INHIBIT) high.
- 7. Hardware controlled charging inhibit is asserted (MODE low with V_{DD5} high). Refer to “Section 6.2”.
- 8. The thermistor of the battery being charged indicates COLD-RANGE and the battery has been charged for longer than $t_{TIMEOUT}$.
- 9. The thermistor of the battery being charged indicates UNDER-RANGE and the battery has been charged for longer than $t_{TIMEOUT}$.
- 10. The thermistor of the battery being charged indicates HOT-RANGE.
- 11. Any SMBus communication line is held low for longer than t_{QUERY} .
- 12. BatterySystemStateCont(POWER_NOT_GOOD) is high.
- 13. The emergency turn-off feature has been asserted using the DCDIV input pin.

3.3 Wake-Up Charging Current and Voltage Limits

The wake-up charging current is fixed at I_{WAKE_UP} for all values of I_{LIMIT} . Wake-up charging uses the low current mode described in “Section 10”.

The wake-up charging voltage is not limited by the V_{LIMIT} function.

3.4 Controlled Charging Initiation

All of the following conditions must be met in order to allow controlled charging of a given battery. One or both batteries may be controlled charged at a time.

1. The battery thermistor must be COLD-RANGE, IDEAL-RANGE, or UNDER-RANGE.
2. AC must be present.
3. BatterySystemStateCont(CHARGING_INHIBIT) must be de-asserted (or low).
4. Hardware controlled charging inhibit must be de-asserted (MODE not low with V_{DD5} high). Refer to “Section 6.2”.
5. The battery responds to an LTC1760 Master read of Alarm() with all charge alarms deasserted.
6. The battery responds to an LTC1760 Master read of ChargingVoltage() with a non zero voltage request value.
7. The battery responds to an LTC1760 Master read of Voltage().
8. The battery responds to an LTC1760 Master read of ChargingCurrent() with a non zero current request value.
9. The battery responds to an LTC1760 Master read of Current().

The following charging related functions are polled each t_{QUERY} : Alarm(), ChargingVoltage(), Voltage(), ChargingCurrent(), and Current().

3.5 Controlled Charging Termination

The LTC1760 will terminate controlled charging when any of the following conditions are met:

1. Battery removal, or thermistor indicating OVER-RANGE.
2. AC removal.
3. The SMBus Host issues a calibration request by setting BatterySystemStateCont(CALIBRATE) high.
4. An LTC1760 Master read of ChargingCurrent() returning a zero current request.
5. An LTC1760 Master read of ChargingVoltage() returning a zero voltage request.
6. Any of the following AlarmWarning() bits asserted high:

OVER_CHARGED_ALARM
 TERMINATE_CHARGE_ALARM
 TERMINATE_CHARGE_RESERVED
 OVER_TEMP_ALARM

Note that the LTC1760 ignores all writes from the battery. Each battery’s charge alarm is cached inside the LTC1760. This internally cached bit will be set when any of the upper four bits of the battery’s AlarmWarning() response are set.

OPERATION

This cached bit will remain set if a subsequent AlarmWarning() fails to respond. The cached alarm will be cleared by any of the following conditions.

- a) Associated battery is removed.
 - b) A subsequent AlarmWarning() clears all charge alarm bits for the associated battery.
 - c) A power on reset event.
 - d) The SMBus Host asserts BatterySystemStateCont(CHARGER_POR) high.
7. The SMBus Host asserts BatterySystemStateCont(CHARGING_INHIBIT) high.
 8. Hardware controlled charging inhibit is asserted (MODE low with V_{DDS} high).
 9. The SMBus of the battery being charged has stopped acknowledging SMBus read commands for longer than t_{TIMEOUT}.
 10. The thermistor of the battery being charged indicates HOT-RANGE.
 11. Any SMBus communication line is grounded for longer than t_{QUERY}.
 12. BatterySystemStateCont(POWER_NOT_GOOD) is high.
 13. The emergency turn-off feature has been asserted using the DCDIV input pin.

Whenever changing conditions cause either battery to stop charging, charging is stopped immediately for all batteries and the voltage and current algorithms are reset to zero. Charging is not resumed until all the conditions for controlled charging are met.

3.6 Controlled Charging Current Programming

The LTC1760 uses a single charger stage to simultaneously charge up to two batteries. The batteries are connected to the charger using a charge MUX. The charge MUX allows the total charger current to be shared by the two batteries while preventing charge transfer between the batteries. Refer to “Section 7.1” and “Section 7.2”.

When charging a single battery, the charging algorithm attempts to adjust the current so as to match the reported current with the requested current. The LTC1760 continuously adjusts the charging current by the difference between the actual and requested currents.

When simultaneously charging two batteries, the charging algorithm attempts to adjust the current so as to match the reported current with the requested current in both batteries. The LTC1760 calculates the difference between the requested and actual current in both batteries and uses the minimum of these differences to increment or decrement the total charge current being provided by the charging stage.

The charging algorithm will not allow the reported actual current to exceed the requested current in either battery. For this reason the most efficient charging occurs for matched batteries at similar charge states.

Whenever changing conditions cause either battery to stop charging, the current algorithm is reset to zero. The programmed current is updated every t_{QUERY}.

There are additional safety restrictions that limit the total output current of the charger. These are detailed in the following three sub-sections.

3.6.1 Current Limits When Charging A Single Battery

The following additional limits are applied to the charging current algorithm described in 3.6 when charging a single battery:

- a) The programmed current cannot exceed the requested current + I_{LIMIT}/32.
- b) The programmed current cannot exceed I_{LIMIT}.

3.6.2 Current Limits When Charging Two Batteries (TURBO Mode Disabled)

The following additional limits are applied to the charging current algorithm described in 3.6 when charging two batteries with turbo mode disabled:

- a) The programmed current cannot exceed the maximum of the two requested currents + I_{LIMIT}/32.
- b) The programmed current cannot exceed I_{LIMIT}.

OPERATION

3.6.3 Current Limits When Charging Two Batteries (TURBO Mode Enabled)

The following additional limits are applied to the charging current algorithm described in 3.6 when charging two batteries with turbo mode enabled:

- The programmed current cannot exceed the maximum of the two requested currents + I_{LIMIT} . This relaxed limit enables accelerated charging if I_{LIMIT} is greater than the maximum of the two requested currents. For the recommended matched battery pair the requested current should be the same.
- The programmed current cannot exceed I_{LIMIT}

TURBO mode provides a mechanism for the SMBus Host to enable the charge MUX to apply additional current to both batteries. TURBO mode only has an effect when two batteries are being charged simultaneously. TURBO mode does not affect wake-up charging or any other conditions that could inhibit charging. TURBO mode is entered when LTC(TURBO) is set high.

Normally the LTC1760 will limit the current into both batteries to the maximum of the two requested currents + $I_{LIMIT}/32$. TURBO mode removes this restriction, allowing the charger to output as much as I_{LIMIT} into the combined battery system.

For example: In a system where LTC(TURBO)=0, $I_{LIMIT}=4.0A$ and each battery is requesting 2A the LTC1760 will not output more than 2.125A into the combined battery system or 1.06A into each battery if their charge states match. In a system where LTC(TURBO)=1, $I_{LIMIT}=4.0A$ and each battery is requesting 2A the LTC1760 will now output up to I_{LIMIT} into the combined battery system or 2A into each battery if their charge states match.

Even without TURBO mode, the LTC1760 offers significantly reduced charge times for matched batteries in the top-off state. This time savings is especially significant for Lithium-Ion batteries. Simultaneously charging two batteries reduces losses in switches and improves efficiency.

3.7 Controlled Charging Voltage Programming

The LTC1760 monitors the requested and actual voltages in each battery and increments the programmed voltage

by 16mV each t_{QUERY} unless one of the following conditions are met:

- The actual voltage exceeds the requested voltage in either battery.
- The actual voltage exceeds V_{LIMIT} .

This is an extremely important feature of the LTC1760 since it allows the charger to servo on the internal cell voltage of the battery as determined by the Smart Battery. This voltage may be significantly lower than the battery pack terminal voltage which is used by all Level 2 chargers. The advantage for the LTC1760 is improved charge time, safety, and a more completely charged battery.

The voltage correction cannot exceed the minimum requested voltage by more than 512mV. When decrementing, the programmed voltage is reduced by 16mV each t_{QUERY} . Whenever changing conditions cause either battery to stop charging, the voltage algorithm is reset to zero.

4 System Power Management Algorithm and Battery Calibration

4.1 Turning Off System Power

The LTC1760 allows the user to turn off system power using the LTC(POWER_OFF) bit. When POWER_OFF is asserted high all power management functions are bypassed and the LTC1760 will turn off DCIN, BAT2 and BAT1 power paths. This feature allows the user to power down the system. Charging is still allowed when POWER_OFF is asserted high.

4.2 Power-By Algorithm When No Battery is Being Calibrated

The LTC1760 will always attempt to maintain system power. The preferred configuration is to remain in 3-Diode mode. In 3-Diode mode, power will be provided by BAT1, BAT2 and DCIN with the source at the highest voltage potential automatically providing all the power. Sources at similar voltage potentials will share power based on their capacity.

The following conditions will cause the LTC1760 to modify its preferred power-by algorithm.

OPERATION

1. A battery issues a TERMINATE_DISCHARGE alarm and AC_PRESENT is high. The LTC1760 will select the other battery and DCIN to power the system.
2. A battery issues a TERMINATE_DISCHARGE alarm and AC_PRESENT is low. The LTC1760 will select the other battery to power the system.
3. A battery issues a TERMINATE_DISCHARGE alarm, AC_PRESENT is low, and the other battery is not present or has previously issued an alarm. The LTC1760 will autonomously try to restore power by entering 3-Diode mode. The 3-Diode mode will ignore TERMINATE_DISCHARGE and FULLY_DISCHARGED alarms.

4.3 Power-By Algorithm When a Battery is Being Calibrated

During battery calibration, the battery being calibrated is the only device powering the system. This will be reflected in the reported POWER_BY[4:1] bits. See “Section 5” for more information on battery calibration.

4.4 Power-By Reporting

The following tables illustrate how BatterySystemStateCont(POWER_BY_BAT[4:1]) interprets PowerPath conditions.

Power Reporting for Batteries Being Calibrated

AC_PRESENT	CALIBRATE_BAT2	CALIBRATE_BAT1	POWERED_BY_BAT(4:1)
1	0	0	0000b
1	1	1	0001b
1	1	0	0010b

*States not shown are not allowed

Power Reporting as a Function of Battery Presence

AC_PRESENT	PRESENT_BAT2	PRESENT_BAT1	POWERED_BY_BAT(4:1)
1	X	X	0000b
0	0	0	0000b
0	0	1	0001b
0	1	0	0010b
0	1	1	0011b

Power Reporting with AC_PRESENT Low and both Batteries Present, as a Function of Power Alarms.

AC_PRESENT	BATTERY 2 POWER ALARM (NOTE 1)	BATTERY 1 POWER ALARM (NOTE 1)	POWERED_BY_BAT(4:1)
0	0	0	0011b
0	0	1	0010b
0	1	0	0001b
0	1	1	0011b
1	X	X	0000b

Note 1: A power alarm means that ALARM() has returned TERMINATE_DISCHARGE=1 or FULLY_DISCHARGED_ALARM=1

Power Reporting When BatterySystemStateCont(POWER_NOT_GOOD) is High and the LTC1760 has Autonomously Entered 3-Diode Mode

AC_PRESENT	PRESENT_BAT2	PRESENT_BAT1	POWERED_BY_BAT(4:1)
0	0	0	0000b
0	0	1	0001b
0	1	0	0010b
0	1	1	0011b
1	0	0	0000b
1	0	1	0000b
1	1	0	0000b
1	1	1	0000b

5 Battery Calibration (Conditioning)

Calibration allows the SMBus Host to fully discharge a battery for conditioning purposes. The SMBus Host may determine the battery to be discharged or allow the LTC1760 to choose based on the batteries’ request to be conditioned.

5.1 Selecting a Battery to be Calibrated

Option 1) SMBus Host chooses battery to be calibrated using BatterySystemStateCont(CALIBRATE_BAT[4:1])

Allowed values:

0001b: Set CALIBRATE_BAT1. Only has an effect if Battery 1 BatteryMode(CONDITION_FLAG) is high. May not be updated if a calibration is in progress.

0010b: Set CALIBRATE_BAT2. Only has an effect if Battery 2 BatteryMode(CONDITION_FLAG) is high. May not be updated if a calibration is in progress.

OPERATION

0000b: Clears CALIBRATE_BAT1 and CALIBRATE_BAT2 and allows LTC1760 to choose. Power on reset default. May not be updated if a calibration is in progress.

Option 2) SMBus Host allows LTC1760 to choose battery to be calibrated.

BatterySystemStateCont(CALIBRATE_BAT[4:1]) = 0000b. See previous option.

The LTC1760 determines that the battery requires calibration by reading BatteryMode(CONDITION_FLAG). This flag is cached in the LTC1760. The LTC1760 sets BatterySystemStateCont(CALIBRATE_REQUEST) high. The LTC1760 will always select the battery that is requesting calibration. If both batteries are requesting calibration, the LTC1760 will select Battery 1. If neither battery is requesting calibration, then calibration cannot occur.

5.2 Initiating Calibration of Selected Battery

The SMBus Host initiates a calibration by writing to BatterySystemStateCont(CALIBRATE). Follow rules of the previous section to preserve battery intended for calibration. The SMBus Host must only set the calibration bit once per calibration.

The LTC1760 will discharge the selected battery as long as the calibration is in progress (CALIBRATE high). Updates to the cached BatteryMode(CONDITION_FLAG) will be inhibited while CALIBRATE is asserted. This means that discharge of the battery will continue even if the battery clears the CONDITION_FLAG.

5.3 Terminating Calibration of Selected Battery

Calibration will end when CALIBRATE is cleared. CALIBRATE will be cleared when:

- AC is removed.
- The battery being calibrated is removed. When the battery being calibrated is removed, the LTC1760 will automatically calibrate the other battery if it is requesting calibration.
- BatterySystemStateCont(POWER_NOT_GOOD) is high.

- The battery sets Alarm Warning(TERMINATE_DISCHARGE) high.
- The battery sets Alarm Warning (FULLY_DISCHARGED) high.
- A zero is written to the CALIBRATE bit.

The LTC1760 will attempt to initiate a charge cycle after the discharge cycle is completed.

6 MODE Pin Operation

The MODE pin is a multifunction pin that allows the LTC1760 to: 1) display charging status in stand alone operation; 2) activate hardware charge inhibit; 3) charge when SCL and SDA are low and; 4) charge with an SMBus Host.

Summary of SDA, SCL and SMBALERT Operation as a Function of MODE and V_{DD5} Levels

CONDITION	LTC1760 OPERATING MODE
$V_{MODE} = GND$ $V_{VDD5} < V_{IL_VDD5}$	SCL: Clock for Status Indicators SCL: Clock for Status Indicators SDA: Battery 2 Status SMBALERT: Battery 1 Status
$V_{MODE} = GND$ $V_{VDD5} > V_{IH_VDD5}$	SCL, SDA, SMBALERT: Normal Operation LTC1760 Charging Inhibited
$V_{MODE} = V_{VCC2}$ $V_{VDD5} < V_{IL_VDD5}$	SCL, SDA Ignored and May Float Low SMBALERT: Normal Operation SCL1, SDA1, SCL2 and SDA2: Normal Operation and Charging is Allowed
$V_{MODE} = V_{VCC2}$ $V_{VDD5} > V_{IH_VDD5}$	Normal Operation on all Pins, Charging is Allowed

6.1 Standalone Charge Indication

When MODE is tied to GND and $V_{VDD5} < V_{IL_VDD5}$, the function of SDA, SMBALERT, and SCL are changed as described below:

SDA is an output and is used to monitor charging status of Battery 2. Allowed values are:

Low: Battery 2 is charging.

High: Battery 2 not charging (AC is not present or battery is not present).

Blinking: Battery 2 charge complete (AC is present, battery is present and not charging).

OPERATION

$\overline{\text{SMBALERT}}$ is used to monitor charging status of Battery 1. Allowed values are:

Low: Battery 1 is charging.

High: Battery 1 not charging (AC is not present or battery is not present).

Blinking: Battery 1 charge complete (AC is present, battery is present and not charging).

SCL is an input and is used to determine the blinking rate of SDA and $\overline{\text{SMBALERT}}$. Tie SCL high if blinking is not desired. This will provide two different states to indicate charging (output low) and not charging (output high).

6.2 Hardware Charge Inhibit

When MODE is tied to GND and $V_{\text{VDD5}} > V_{\text{IH_VDD5}}$, charging is inhibited and BatterySystemStateCont(CHARGING_INHIBIT) will report a logic high.

6.3 Charging When SCL And SDA Are Low

When MODE is tied to V_{CC2} and $V_{\text{VDD5}} < V_{\text{IL_VDD5}}$, SDA and SCL are not used and will not interfere with LTC1760 battery communication. This feature allows the LTC1760 to autonomously charge when SCL and SDA are not available. This scenario might occur when SMBus Host has powered down and is no longer pulling up on SCL and SDA.

6.4 Charging With an SMBus Host

When Mode is tied to V_{CC2} and $V_{\text{VDD5}} > V_{\text{IH_VDD5}}$, SDA and SCL are used to communicate with the SMBus Host.

7 Battery Charger Controller

The LTC1760 charger controller uses a constant off-time, current mode step-down architecture. During normal operation, the top MOSFET is turned on each cycle when the oscillator sets the SR latch and turned off when the main current comparator I_{CMP} resets the SR latch. While the top MOSFET is off, the bottom MOSFET is turned on until either the inductor current trips the current comparator I_{REV} , or the beginning of the next cycle. The oscillator uses the equation:

$$t_{\text{OFF}} = (V_{\text{DCIN}} - V_{\text{BAT}}) / (V_{\text{DCIN}} \cdot f_{\text{OSC}})$$

to set the bottom MOSFET on time. The result is quasi-constant frequency operation where the converter frequency remains nearly constant over a wide range of output voltages. This activity is diagrammed in Figure 4.

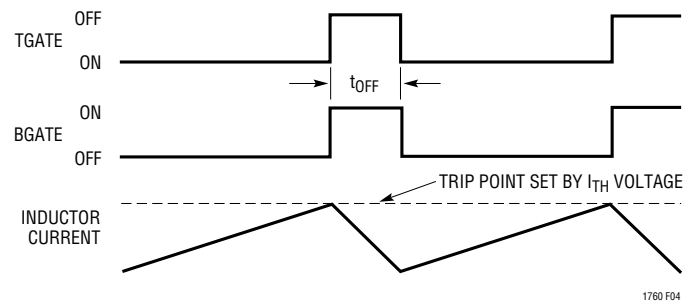

Figure 4.

The peak inductor current, at which I_{CMP} resets the SR latch, is controlled by the voltage on I_{TH} . I_{TH} is in turn controlled by several loops, depending upon the situation at hand. The average current control loop converts the voltage between CSP and BAT to a representative current. Error amp CA2 compares this current against the desired current programmed by the I_{DAC} at the I_{SET} pin and adjusts I_{TH} for the desired voltage across R_{SENSE} .

The voltage at BAT is divided down by an internal resistor divider set by the V_{DAC} and is used by error amp EA to decrease I_{TH} if the divider voltage is above the 0.8V reference.

The amplifier CL1 monitors and limits the input current, normally from the AC adapter, to a preset level (100 mV/ R_{CL}). At input current limit, CL1 will decrease the I_{TH} voltage and thus reduce battery charging current.

An over-voltage comparator, OV, guards against transient overshoots (>7.5%). In this case, the top MOSFET is turned off until the over-voltage condition is cleared. This feature is useful for batteries which “load dump” themselves by opening their protection switch to perform functions such as calibration or pulse-mode charging.

The top MOSFET driver is powered from a floating bootstrap capacitor C4. This capacitor is normally recharged from V_{CC} through an external diode when the top MOSFET is turned off. As V_{IN} decreases towards the selected

OPERATION

battery voltage, the converter will attempt to turn on the top MOSFET continuously (“dropout”). A dropout timer detects this condition and forces the top MOSFET to turn off, and the bottom MOSFET on, for about 200ns at 40 μ s intervals to recharge the bootstrap capacitor.

7.1 Charge MUX Switches

The equivalent circuit of a charge MUX switch driver is shown in Figure 5. If the charger controller is not enabled, the charge MUX drivers will drive the gate and source of the series-connected MOSFETs to a low voltage and the switch is off. When the charger controller is on, the charge MUX driver will keep the MOSFETs off until the voltage at CSN rises at least 35mV above the battery voltage. GCH1 is then driven with an error amplifier EAC until the voltage between BAT1 and CSN satisfies the error amplifier or until GCH1 is clamped by the internal Zener diode. The time required to close the switch could be quite long (many ms) due to the small currents output by the error amp and depending upon the size of the MOSFET switch.

If the voltage at CSN decreases below $V_{BAT1} - 20mV$ a comparator CC quickly turns off the MOSFETs to prevent reverse current from flowing in the switches. In essence, this system performs as a low forward voltage diode.

Operation is identical for BAT2.

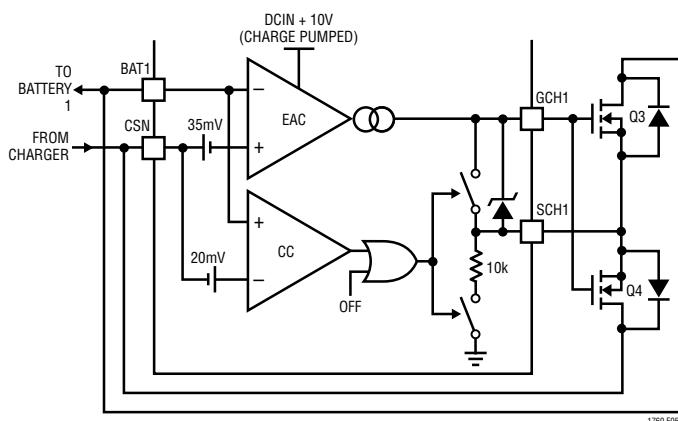

Figure 5. Charge MUX Switch Driver Equivalent Circuit

7.2 Dual Charging

Note that the charge MUX switch drivers will operate together to allow both batteries to be charged simultaneously. If both charge MUX switch drivers are enabled, only the battery with the lowest voltage will be charged until its voltage rises to equal the higher voltage battery. The charge current will then share between the batteries according to the capacity of each battery.

When batteries are controlled charging, only batteries with voltages above V_{CHMIN} are allowed to charge. When a battery is wake-up charging this restriction does not apply.

8 PowerPath Controller

The PowerPath switches are turned on and off by the power management algorithm. The external PFETs are usually connected as an input switch and an output switch. The output switch PFET is connected in series with the input PFET and the positive side of the short-circuit sensing resistor, R_{SC} . The input switch is connected in series between the power source and the output PFET. The PowerPath switch driver equivalent circuit is shown in Figure 6. The output PFET is driven ON or OFF by the output side driver controlling pin GB10. The gate of the input PFET is driven by an error amplifier which monitors the voltage between the input power source (BAT1 in this case) and SCP. If the switch is turned off, the two outputs are driven to the higher of the two voltages present across the input/SCP terminals of the switch. When the switch is instructed to turn on, the output side driver immediately drives the gate of the output PFET approximately 6V below the highest of the voltages present at the input/SCP. When the output PFET turns on, the voltage at SCP will be pulled up to a diode drop below the source voltage by the bulk diode of the input PFET. If the source voltage is more than 25mV above SCP, EAP will drive the gate of the input PFET low until the input PFET turns on and reduces the voltage across the input/SCP to the EAP set point, or until the Zener clamp engages to limit the voltage applied to the input PFET. If the source voltage drops more than 20mV below SCP, then comparator CP turns on SWP to quickly prevent large reverse current in the switch. This operation mimics a diode with a low forward voltage drop.

OPERATION

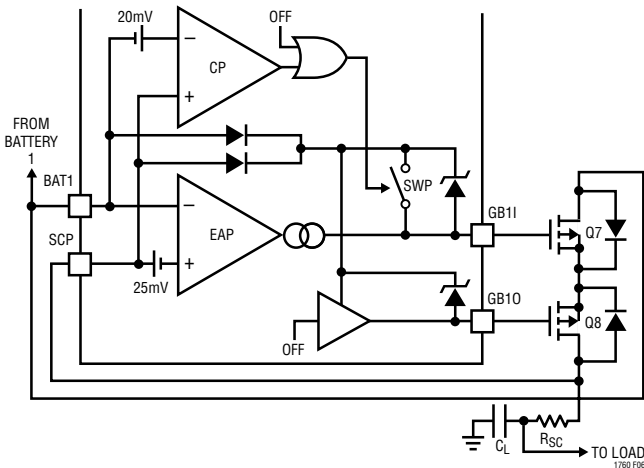

Figure 6. PowerPath Driver Equivalent Circuit

8.1 Autonomous PowerPath Switching

The LOPWR comparator monitors the voltage at the load through the resistor divider from pin SCN. If LTC (POWER_OFF) is low and the LOPWR comparator trips, then all of the switches are turned on (3-Diode mode) by the Autonomous PowerPath Controller to ensure that the system is powered from the source with the highest voltage. The Autonomous PowerPath Controller waits approximately 1 second, to allow power to stabilize, and then reverts back to the PowerPath switch configuration requested by the PowerPath Management Algorithm. A power fail counter is incremented to indicate that a failure has occurred. If the power fail counter equals a value of 3, then the the Autonomous PowerPath Controller sets the switches to 3-Diode mode and BatterySystemStateCont(POWER_NOT_GOOD) will be set, provided the LOPWR comparator is still detecting a low power event. This is a three-strikes-and-you're-out process which is intended to debounce the POWER_NOT_GOOD indicator. The power fail counter is reset when battery or AC presence change.

8.2 Short-Circuit Protection

Short-circuit protection operates in both a current mode and a voltage mode. If the voltage between SCP and

SCN exceeds the short-circuit comparator threshold V_{TSC} for more than 15ms, then all of the PowerPath switches are turned off and BatterySystemState-Cont (POWER_NOT_GOOD) is set. Similarly, if the voltage at SCN falls below 3V for more than 15ms, then all of the PowerPath switches are turned off and POWER_NOT_GOOD is set high. The POWER_NOT_GOOD bit is reset by removing all power sources and allowing the voltage at V_{PLUS} to fall below the UVLO threshold. If the POWER_NOT_GOOD bit is set, charging is disabled until V_{PLUS} exceeds the UVLO threshold and the Charger Algorithm allows charging to resume.

When a hard short-circuit occurs, it might pull all of the power sources down to near 0V potentials. The capacitors on V_{CC} and V_{PLUS} must be large enough to keep the circuit operating correctly during the 15ms short-circuit event. The charger will stop within a few microseconds, leaving a small current which must be provided by the capacitor on V_{PLUS} . The recommended minimum values (1 μ F on V_{PLUS} and 2 μ F on V_{CC} , including tolerances) should keep the LTC1760 operating above the UVLO trip voltage long enough to perform the short-circuit function when the input voltages are greater than 8V. Increasing the capacitor across V_{CC} to 4.7 μ F will allow operation down to the recommended 6V minimum.

8.3 Emergency Turn-Off

All of the PowerPath switches can be forced off by setting the DCDIV pin to a voltage between 8V and 10V. This will have the same effect as a short-circuit event. DCDIV must be less than 5V and V_{PLUS} must decrease below the UVLO threshold to re-enable the PowerPath switches. The LTC1760 can recover from this condition without removing power. Contact Applications Engineering for more information.

8.4 Power-Up Strategy

All three PowerPath switches are turned on after V_{PLUS} exceeds the UVLO threshold for more than 250ms. This delay is to prevent oscillation from a turn-on transient near the UVLO threshold.

OPERATION

9 The Voltage DAC Block

The voltage DAC (V_{DAC}) is a delta-sigma modulator which controls the effective value of an internal resistor, $R_{VSET} = 7.2k$, used to program the maximum charger voltage. Figure 7 is a simplified diagram of the V_{DAC} operation. The delta-sigma modulator and switch SWV convert the V_{DAC} value to a variable resistance equal to $(11/8)R_{VSET}/(V_{DAC(VALUES)}/2047)$. In regulation, V_{SET} is servo driven to the 0.8V reference voltage, V_{REF} .

Capacitors C_{B1} and C_{B2} are used to average the voltage present at the V_{SET} pin as well as provide a zero in the voltage loop to help stability and transient response time to voltage variations.

10 The Current DAC Block

The current DAC is a delta-sigma modulator which controls the effective value of an internal resistor, $R_{SET} = 18.77k$, used to program the maximum charger current. Figure 8 is a simplified diagram of the DAC operation. The delta-sigma

modulator and switch convert the I_{DAC} value to a variable resistance equal to $1.25R_{SET}/(I_{DAC(VALUES)}/1023)$. In regulation, I_{SET} is servo driven to the 0.8V reference voltage, V_{REF} , and the current from R_{SET} is matched against a current derived from the voltage between pins CSP and CSN. This current is $(V_{CSP} - V_{CSN})/3k$.

Therefore programmed current is:

$$I_{CHG} = V_{REF} \cdot 3k / (1.25 R_{SNS} R_{SET}) \cdot (I_{DAC(VALUES)}/1023) \\ = (102.3mV/R_{SNS}) \cdot (I_{DAC(VALUES)}/1023)$$

During wake-up current operation, the current DAC enters a low current mode. The current DAC output is pulse-width modulated with a high frequency clock having a duty cycle value of 1/8. Therefore, the maximum output current provided by the charger is $I_{MAX}/8$. The delta-sigma output gates this low duty cycle signal on and off. The delta-sigma shift registers are then clocked at a slower rate, about 40ms/bit, so that the charger has time to settle to the $I_{MAX}/8$ value.

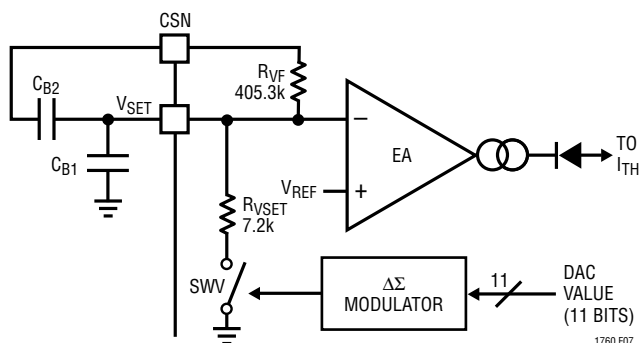

Figure 7. Voltage DAC Operation

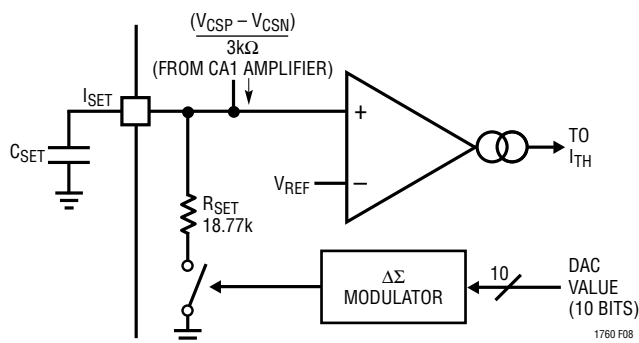

Figure 8. Current Dac Operation

APPLICATIONS INFORMATION

Automatic Current Sharing

In a dual parallel charge configuration, the LTC1760 does not actually control the current flowing into each individual battery. The capacity, or Amp-Hour rating, of each battery determines how the charger current is shared. This automatic steering of current is what allows both batteries to reach their full capacity points at the same time. In other words, given all other things equal, charge termination will happen simultaneously.

A battery can be modeled as a huge capacitor and hence governed by the same laws.

$I = C \cdot (dV/dt)$ where:

I = The current flowing through the capacitor

C = Capacity rating of battery (using amp-hour values instead of capacitance)

dV = Change in voltage

dt = Change in time

The equivalent model of a set or parallel batteries is a set of parallel capacitors. Since they are in parallel, the change in voltage over change in time is the same for both batteries 1 and 2.

$$dV/dt_{BAT1} = dV/dt_{BAT2}$$

From here we can simplify.

$$I_{BAT1}/C_{BAT1} = dV/dt = I_{BAT2}/C_{BAT2}$$

$$I_{BAT2} = I_{BAT1} C_{BAT2}/C_{BAT1}$$

At this point you can see that the current divides as the ratio of the two batteries capacity ratings. The sum of the current into both batteries is the same as the current being supply by the charger. This is independent of the mode of the charger (CC or CV).

$$I_{CHRG} = I_{BAT1} + I_{BAT2}$$

From here we solve for the actual current for each battery.

$$I_{BAT2} = I_{CHRG} C_{BAT2}/(C_{BAT1} + C_{BAT2})$$

$$I_{BAT1} = I_{CHRG} C_{BAT1}/(C_{BAT1} + C_{BAT2})$$

Please note that the actual observed current sharing will vary from manufacturer's claimed capacity ratings since

it is actual physical capacity rating at the time of charge. Capacity rating will change with age and use and hence the current sharing ratios can change over time.

Adapter Limiting

An important feature of the LTC1760 is the ability to automatically adjust charging current to a level which avoids overloading the wall adapter. This allows the product to operate at the same time that batteries are being charged without complex load management algorithms. Additionally, batteries will automatically be charged at the maximum possible rate of which the adapter is capable.

This feature is created by sensing total adapter output current and adjusting charging current downward if a preset adapter current limit is exceeded. True analog control is used, with closed loop feedback ensuring that adapter load current remains within limits. Amplifier CL1 in Figure 9 senses the voltage across R_{CL} , connected between the CLP and DCIN pins. When this voltage exceeds 100mV, the amplifier will override programmed charging current to limit adapter current to $100mV/R_{CL}$. A lowpass filter formed by $5k\Omega$ and $0.1\mu F$ is required to eliminate switching noise. If the current limit is not used, CLP should be connected to DCIN.

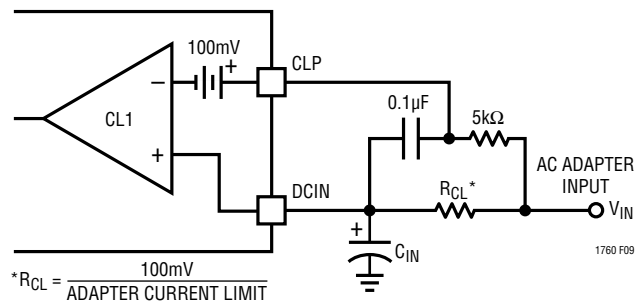

Figure 9.

Setting Input Current Limit

To set the input current limit, you need to know the minimum wall adapter current rating. Subtract 5% for the input current limit tolerance and use that current to determine the resistor value.

$$R_{CL} = 100mV/I_{LIM}$$

$$I_{LIM} = \text{Adapter Min Current} - (\text{Adapter Min Current} \cdot 5\%)$$

APPLICATIONS INFORMATION

As is often the case, the wall adapter will usually have at least a +10% current limit margin and many times one can simply set the adapter current limit value to the actual adapter rating (see Figure 9 & Table 1).

Table 1. Common R_{CL} Resistor Values

Adapter Rating A	RCL Value* (Ω) 1%	RCL Power Dissipation (W)	RCL Power Rating (W)
1.5	0.06	0.135	0.25
1.8	0.05	0.162	0.25
2	0.045	0.18	0.25
2.3	0.039	0.206	0.25
2.5	0.036	0.225	0.5
2.7	0.033	0.241	0.5
3	0.030	0.21	0.5

*Values shown above are rounded to nearest standard value. Table 1 RCL values take into account LTC1760 C-grade 5% tolerance for VCL1.

Extending System to More than 2 Batteries

The LTC1760 can be extended to manage systems with more than 3 sources of power. Contact Linear Technology Applications Engineering for more information.

Charge Termination Issues

Batteries with constant-current charging and voltage-based charger termination might experience problems with reductions of charger current caused by adapter limiting. It is recommended that input limiting feature be defeated in such cases. Consult the battery manufacturer for information on how your battery terminates charging.

Setting Charger Output Current Limit

The LTC1760 current DAC and the PWM analog circuitry must coordinate the setting of the charger current. Failure to do so will result in incorrect charge currents.

Table 2. Recommended Resistor Values

I _{MAX} (A)	R _{SENSE} (Ω) 1%	R _{SENSE} (W)	R _{ILIMIT} (Ω) 1%
1	0.100	0.25	0
2	0.05	0.25	10k
3	0.025	0.5	33k
4	0.025	0.5	Open or short to V _{CC2}

Warning

DO NOT CHANGE THE VALUE OF R_{ILIMIT} DURING OPERATION. The value must remain fixed and track the R_{SENSE} value at all times. Changing the current setting can result in currents that greatly exceed the requested value and potentially damage the battery or overload the wall adapter if no input current limiting is provided.

Setting Charger Output Voltage Limit

The value of an external resistor connected from the V_{LIMIT} pin to GND determines one of five voltage limits that are applied to the charger output value. See Table 3. These limits provide a measure of safety with a hardware restriction on charging voltage, which cannot be overridden by software. This voltage sets the limit that will be applied to the battery as reported by battery. Since the battery internal voltage monitor point is the actual cell voltage, you may see higher voltages, up to 512mV higher, at the external charger terminals due to the voltage servo loop action. See Operations “Section 3.7” for more information on the voltage servo system.

Table 3. Recommended Resistor Values for R_{VLIMIT}

V _{MAX}	R _{VLIMIT} (Ω) 1%
Up to 8.4V	0 (Short to ground)
Up to 12.6V	10k
Up to 16.8V	33k
Up to 21.0V	100k
Up to 32.7V (No Limit)	Open or short to V _{CC2}

Inductor Selection

Higher operating frequencies allow the use of smaller inductor and capacitor values. A higher frequency generally results in lower efficiency because of MOSFET gate charge losses. In addition, the effect of inductor value on ripple current and low current operation must also be considered. The inductor ripple current ΔI_L decreases with higher frequency and increases with higher V_{IN}.

$$\Delta I_L = \frac{1}{(f)(L)} V_{OUT} \left(1 - \frac{V_{OUT}}{V_{IN}} \right)$$

Accepting larger values of ΔI_L allows the use of low inductances, but results in higher output voltage ripple

APPLICATIONS INFORMATION

and greater core losses. A reasonable starting point for setting ripple current is $\Delta I_L = 0.4(I_{MAX})$. In no case should ΔI_L exceed $0.6(I_{MAX})$ due to limits imposed by IREV and CA1. Remember the maximum ΔI_L occurs at the maximum input voltage. In practice 10 μ H is the lowest value recommended for use.

Charger Switching Power MOSFET and Diode Selection

Two external power MOSFETs must be selected for use with the LTC1760 charger: An N-channel MOSFET for the top (main) switch and an N-channel MOSFET for the bottom (synchronous) switch.

The peak-to-peak gate drive levels are set by the V_{CC} voltage. This voltage is typically 5.2V. Consequently, logic-level threshold MOSFETs must be used. Pay close attention to the V_{DSS} specification for the MOSFETs as well; many of the logic level MOSFETs are limited to 30V or less.

Selection criteria for the power MOSFETs include the “ON” resistance $R_{DS(ON)}$, reverse transfer capacitance C_{RSS} , input voltage and maximum output current. The LTC1760 charger is always operating in continuous mode so the duty cycles for the top and bottom MOSFETs are given by:

$$\text{Main Switch Duty Cycle} = V_{OUT}/V_{IN}$$

$$\text{Synchronous Switch Duty Cycle} = (V_{IN} - V_{OUT})/V_{IN}$$

The MOSFET power dissipations at maximum output current are given by:

$$P_{MAIN} = V_{OUT}/V_{IN}(I_{MAX})^2(1 + \delta\Delta T)R_{DS(ON)} + k(V_{IN})^2(I_{MAX})(C_{RSS})(f)$$

$$P_{SYNC} = (V_{IN} - V_{OUT})/V_{IN}(I_{MAX})^2(1 + \delta\Delta T)R_{DS(ON)}$$

Where $\delta\Delta T$ is the temperature dependency of $R_{DS(ON)}$ and k is a constant inversely related to the gate drive current. Both MOSFETs have I^2R losses while the topside N-channel equation includes an additional term for transition losses, which are highest at high input voltages. For $V_{IN} < 20V$ the high current efficiency generally improves with larger MOSFETs, while for $V_{IN} > 20V$ the transition losses rapidly increase to the point that the use of a higher $R_{DS(ON)}$ device with lower C_{RSS} actually provides higher efficiency. The synchronous MOSFET losses are greatest

at high input voltage or during a short-circuit when the duty cycle in this switch is nearly 100%. The term $(1 + \delta\Delta T)$ is generally given for a MOSFET in the form of a normalized $R_{DS(ON)}$ vs Temperature curve, but $\delta = 0.005/^\circ C$ can be used as an approximation for low voltage MOSFETs. C_{RSS} is usually specified in the MOSFET characteristics. The constant $k = 1.7$ can be used to estimate the contributions of the two terms in the main switch dissipation equation.

If the LTC1760 charger is to operate in low dropout mode or with a high duty cycle greater than 85%, then the top-side N-channel efficiency generally improves with a larger MOSFET. Using asymmetrical MOSFETs may achieve cost savings or efficiency gains.

The Schottky diode D1, shown in the Typical Application, conducts during the dead-time between the conduction of the two power MOSFETs. This prevents the body diode of the bottom MOSFET from turning on and storing charge during the dead-time, which could cost as much as 1% in efficiency. A 1A Schottky is generally a good size for 4A regulators due to the relatively small average current. Larger diodes can result in additional transition losses due to their larger junction capacitance. The diode may be omitted if the efficiency loss can be tolerated.

Calculating IC Operating Current

This section shows how to use the values supplied in the Electrical Characteristics table to estimate operating current for a given application.

The total IC operating current through $DCIN$ when AC is present and batteries are charging (I_{DCIN_CHG}) is given by:

$$I_{DCIN_CHG} = I_{CH1} + I_{VCC2_AC1} + I_{SAFETY1} + I_{SAFETY2} + I_{VLIM} + I_{ILIM} + I_{SMB} + I_{SMB_BAT1} + I_{SMB_BAT2} + I_{SMBALERT}$$

where:

I_{CH1} is defined in “Electrical Characteristics.”

I_{VCC2_AC1} is defined in “Electrical Characteristics.”

$I_{SAFETYX}$ is the current used to test the battery thermistor connected to SAFETY1 OR SAFETY2.

For thermistors that are OVER-RANGE:

$$I_{SAFETYX} = 2/64 \cdot V_{VCC2}/(R_{XB} + R_{THX})$$

APPLICATIONS INFORMATION

For thermistors that are COLD-RANGE:

$$I_{SAFETYX} = 4/64 \cdot V_{VCC2}/(R_{XB} + R_{THX})$$

For thermistors that are IDEAL-RANGE:

$$I_{SAFETYX} = 4/64 \cdot V_{VCC2}/(R_{XB} + R_{THX}) + 2/64 \cdot V_{VCC2}/(R_{1A} + R_{THX})$$

For thermistors that are HOT-RANGE:

$$I_{SAFETYX} = 4/64 \cdot V_{VCC2}/(R_{XB} + R_{THX}) + 4/64 \cdot V_{VCC2}/(R_{1A} + R_{THX})$$

R_{THX} is the impedance of the battery's thermistor to ground.

$$R_{XB} = 54.9k$$

$$R_{XA} = 1.13k$$

Sample calculation of $I_{SAFETYX}$ with $V_{VCC2} = 5.2V$

Thermistor Impedance R_{THX} (Ω)	Thermistor Range	$I_{SAFETYX}$ (μA)
400	OVER_RANGE	1.05
3.3k	IDEAL_RANGE	42.2
400	UNDER_RANGE	218

$$I_{VLIMIT} = V_{VCC2}/(R_{VLIMIT} + R_{LIM_PU}).$$

$$I_{ILIMIT} = V_{VCC2}/(R_{ILIMIT} + R_{LIM_PU}).$$

R_{LIM_PU} is the typical pull-up impedance at V_{LIMIT} and I_{LIMIT} .

$$R_{LIM_PU} = 34k.$$

R_{VLIMIT} is the value of the resistance from V_{LIMIT} to GND.

R_{ILIMIT} is the value of the resistance from I_{LIMIT} to GND.

I_{SMB} is the current used for communicating with the SMBus Host and depends on the amount of bus traffic.

I_{SMB_BATX} is the current used for communicating with Battery1 or Battery2.

$$I_{SMB_BATX} = 350\mu A \cdot 0.0155 = 5.425\mu A.$$

$I_{SMBALERT}$ is defined in "Electrical Characteristics."

Sample calculation of I_{DCIN_CHG} with two Li-Ion batteries ($R_{THX} = 400$), $R_{VLIMIT} = R_{ILIMIT} = 30k$, $V_{CC2} = 5.2V$, and no SMBus Host communication:

$$\begin{aligned} I_{DCIN_CHG} &= I_{CH1} + I_{VCC2_AC1} + I_{SAFETY1} + I_{SAFETY2} + \\ &I_{VLIM} + I_{ILIM} + I_{SMB} + I_{SMB_BAT1} + I_{SMB_BAT2} + \\ &I_{SMBALERT} \\ &= 1.3mA + 700\mu A + 218\mu A + 218\mu A + 81\mu A + 81\mu A \\ &+ 0\mu A + 5.4\mu A + 5.4\mu A + 0\mu A = 2.62mA \end{aligned}$$

The total operating current through BAT1 and BAT2 when AC is not present (I_{BAT_NOAC}) is given by:

$$I_{BAT_NOAC} = I_{BAT} + I_{VCC2_AC0} + I_{SAFETY1} + I_{SAFETY2} + I_{SMB} + I_{SMB_BAT1_AC0} + I_{SMB_BAT2_AC0} + I_{SMBALERT}$$

where:

I_{BAT} is defined in "Electrical Characteristics."

I_{VCC2_AC0} is defined in "Electrical Characteristics."

$I_{SAFETYX}$ is the current used to test the battery thermistor connected to SAFETY1 or SAFETY2.

$$I_{SAFETYX} = 2/64 \cdot V_{VCC2}/(R_{XB} + R_{THX}).$$

R_{THX} is the impedance of the battery's thermistor to ground.

$$R_{XB} = 54.9k.$$

Sample calculation of I_{SAFETY} with $V_{VCC2} = 5.2V$

Thermistor Impedance R_{THX} (Ω)	Thermistor Range	$I_{SAFETYX}$ (μA)
400	UNDER_RANGE	2.9

$I_{SMB_BATX_AC0}$ is the current used for communicating with Battery1 or Battery2 when AC is not present.

$$I_{SMB_BATX_AC0} = 350\mu A \cdot 0.00687 = 2.404\mu A.$$

I_{SMB} is the current used for communicating with the SMBus Host and depends on the amount of bus traffic.

Sample calculation with two Li-Ion batteries ($R_{THX} = 400$), $V_{CC2} = 5.2V$, and no SMBus Host communication:

$$\begin{aligned} I_{BAT_NOAC} &= I_{BAT} + I_{VCC2_AC0} + I_{SAFETY1} + I_{SAFETY2} + \\ &I_{SMB} + I_{SMB_BAT1_AC0} + I_{SMB_BAT2_AC0} + I_{SMBALERT} \\ &= 175\mu A + 80\mu A + 2.9\mu A + 2.9\mu A + 0\mu A + 2.4\mu A + \\ &2.4\mu A + 0\mu A = 265\mu A \end{aligned}$$

APPLICATIONS INFORMATION

Calculating IC Power Dissipation

The power dissipation of the LTC1760 is dependent upon the gate charge of Q_{TG} and Q_{BG} . (Refer to Typical Application). The gate charge is determined from the manufacturer's data sheet and is dependent upon both the gate voltage swing and the drain voltage swing of the FET.

$$P_D = (V_{DCIN} - V_{VCC}) \cdot f_{OSC} \cdot (Q_{TG} + Q_{BG}) + V_{DCIN} \cdot I_{DCIN_CHG} - V_{VCC} \cdot (I_{SAFETY1} + I_{SAFETY2})$$

where:

I_{DCIN_CHG} , $I_{SAFETY1}$, $I_{SAFETY2}$ are defined in the previous section.

Example:

$$\begin{aligned} V_{VCC} &= 5.2V, V_{DCIN} = 19V, f_{OSC} = 345kHz, Q_{TG} = \\ Q_{BG} &= 15nC, I_{DCIN_CHG} = 2.62mA, I_{SAFETY1} = \\ I_{SAFETY2} &= 218\mu A. \\ P_D &= 190mW \end{aligned}$$

V_{SET}/I_{SET} Capacitors

Capacitor C7 is used to filter the delta-sigma modulation frequency components to a level which is essentially DC. Acceptable voltage ripple at I_{SET} is about 10mV_{P-P}. Since the period of the delta-sigma switch closure, $T_{\Delta\Sigma}$, is about 10 μ s and the internal I_{DAC} resistor, R_{SET} , is 18.77k, the ripple voltage can be approximated by:

$$\Delta V_{ISET} = \frac{V_{REF} \cdot T_{\Delta\Sigma}}{R_{SET} \cdot C7}$$

Then the equation to extract C7 is:

$$\begin{aligned} C7 &= \frac{V_{REF} \cdot T_{\Delta\Sigma}}{\Delta V_{ISET} \cdot R_{SET}} \\ &= 0.8/0.01/18.77k(10\mu s) \approx 0.043\mu F \end{aligned}$$

In order to prevent overshoot during start-up transients the time constant associated with C7 must be shorter than the time constant of C5 at the I_{TH} pin. If C7 is increased to improve ripple rejection, then C5 should be increased proportionally and charger response time to average current variation will degrade.

Capacitors C_{B1} and C_{B2} are used to filter the V_{DAC} delta-sigma modulation frequency components to a level which is essentially DC. C_{B2} is the primary filter capacitor and C_{B1} is used to provide a zero in the response to cancel the pole associated with C_{B2} . Acceptable voltage ripple at V_{SET} is about 10mV_{P-P}. Since the period of the delta-sigma switch closure, $T_{\Delta\Sigma}$, is about 11 μ s and the internal V_{DAC} resistor, R_{VSET} , is 7.2k Ω , the ripple voltage can be approximated by:

$$\Delta V_{VSET} = \frac{V_{REF} \cdot T_{\Delta\Sigma}}{R_{VSET} (C_{B1} \parallel C_{B2})}$$

Then the equation to extract $C_{B1} \parallel C_{B2}$ is:

$$C_{B1} \parallel C_{B2} = \frac{V_{REF} \cdot T_{\Delta\Sigma}}{R_{VSET} \Delta V_{VSET}}$$

C_{B2} should be 10 \times to 20 \times C_{B1} to divide the ripple voltage present at the charger output. Therefore $C_{B1} = 0.01\mu F$ and $C_{B2} = 0.1\mu F$ are good starting values. In order to prevent overshoot during start-up transients the time constant associated with C_{B2} must be shorter than the time constant of C5 at the I_{TH} pin. If C_{B2} is increased to improve ripple rejection, then C5 should be increased proportionally and charger response time to voltage variation will degrade.

Input and Output Capacitors

In the 4A Lithium Battery Charger (Typical Application section), the input capacitor (C_{IN}) is assumed to absorb all input switching ripple current in the converter, so it must have adequate ripple current rating. Worst-case RMS ripple current will be equal to one half of output charging current. Actual capacitance value is not critical. Solid tantalum low ESR capacitors have high ripple current rating in a relatively small surface mount package, *but caution must be used when tantalum capacitors are used for input or output bypass*. High input surge currents can be created when the adapter is hot-plugged to the charger or when a battery is connected to the charger. Solid tantalum capacitors have a known failure mechanism when subjected to very high turn-on surge currents. Only Kemet T495 series of "Surge Robust" low ESR tantalums are rated for high surge conditions such as battery to ground.

APPLICATIONS INFORMATION

The relatively high ESR of an aluminum electrolytic for C15, located at the AC adapter input terminal, is helpful in reducing ringing during the hot-plug event. Refer to AN88 for more information.

Highest possible voltage rating on the capacitor will minimize problems. Consult with the manufacturer before use. Alternatives include new high capacity ceramic (at least 20 μ F) from Tokin, United Chemi-Con/Marcon, et al. Other alternative capacitors include OSCON capacitors from Sanyo.

The output capacitor (C_{OUT}) is also assumed to absorb output switching current ripple. The general formula for capacitor current is:

$$I_{RMS} = \frac{0.29 (V_{BAT}) \left(1 - \frac{V_{BAT}}{V_{DCIN}}\right)}{(L1)(f)}$$

For example:

$$V_{DCIN} = 19V, V_{BAT} = 12.6V, L1 = 10\mu H, \text{ and } f = 300kHz, I_{RMS} = 0.41A.$$

EMI considerations usually make it desirable to minimize ripple current in the battery leads, and beads or inductors may be added to increase battery impedance at the 300kHz switching frequency. Switching ripple current splits between the battery and the output capacitor depending on the ESR of the output capacitor and the battery impedance. If the ESR of C_{OUT} is 0.2 Ω and the battery impedance is raised to 4 Ω with a bead or inductor, only 5% of the current ripple will flow in the battery.

PowerPath and Charge MUX MOSFET Selection

Three pairs of P-channel MOSFETs must be used with the wall adapter and the two battery discharge paths. Two pairs of N-channel MOSFETs must be used with the battery charge path. The nominal gate drive levels are set by the clamp drive voltage of their respective control circuitry. This voltage is typically 6.25V. Consequently, logic-level threshold MOSFETs must be used. Pay close attention to the V_{DSS} specification for the MOSFETs as well; many of the logic level MOSFETs are limited to 30V or less.

Selection criteria for the power MOSFETs include the "ON" resistance $R_{DS(ON)}$, input voltage and maximum output

current. For the N-channel charge path, the maximum current is the maximum programmed current to be used. For the P-channel discharge path maximum current typically occurs at end of life of the battery when using only one battery. The upper limit of $R_{DS(ON)}$ value is a function of the *actual* power dissipation capability of a given MOSFET package that must take into account the PCB layout. As a starting point, without knowing what the PCB dissipation capability would be, derate the package power rating by a factor of two.

$$R_{DS(ON)MAX} = \frac{P_{MOSFET}}{2(I_{MAX})^2}$$

If you are using a dual MOSFET package with both MOSFETs in series, you must cut the package power rating in half again and recalculate.

$$R_{DS(ON)MAX} = \frac{P_{MOSFETDUAL}}{4(I_{MAX})^2}$$

If you use identical MOSFETs for both battery paths, voltage drops will track over a wide current range. The LTC1760 linear 25mV CV drop regulation will not occur until the current has dropped below:

$$I_{LINEARMAX} = \frac{25mV}{2R_{DS(ON)MAX}}$$

However, if you try to use the above equation to determine $R_{DS(ON)}$ to force linear mode at full current, the MOSFET $R_{DS(ON)}$ value becomes unreasonably low for MOSFETs available at this time. The need for the LTC1760 voltage drop regulation only comes into play for parallel battery configurations that terminate charge or discharge using voltage. At first this seems to be a problem, but there are several factors helping out:

1. When batteries are in parallel current sharing, the current flow through any one battery is less than if it is running stand-alone.
2. Most batteries that charge in constant voltage mode, such as Li-ion, charge terminate at a current value of C/10 or less which is well within the linear operation range of the MOSFETs.
3. Voltage tracking for the discharge process does not need such precise voltage tracking values.

APPLICATIONS INFORMATION

The LTC1760 has two transient conditions that force the discharge path P-channel MOSFETs to have two additional parameters to consider. The parameters are gate charge Q_{GATE} and single pulse power capability.

When the LTC1760 senses a LOW_POWER event, all the P-channel MOSFETs are turned on simultaneously to allow voltage recovery due to a loss of a given power source. However, there is a delay in the time it takes to turn on all the MOSFETs. Slow MOSFETs will require more bulk capacitance to hold up all the system's power supply function during the transition and fast MOSFET will require less bulk capacitance. The transition speed of a MOSFET to an on or off state is a direct function of the MOSFET gate charge.

$$t = Q_{GATE}/I_{DRIVE}$$

I_{DRIVE} is the fixed drive current into the gate from the LTC1760 and "t" is the time it takes to move that charge to a new state and change the MOSFET conduction mode. Hence time is directly related to Q_{GATE} . Since Q_{GATE} goes up with MOSFETs of lower $R_{DS(ON)}$, choosing such MOSFETs has a counterproductive increase in gate charge making the MOSFET slower. Please note that the LTC1760 recovery time specification only refers to the time it takes for the voltage to recover to the level just prior to the LOW_POWER event as opposed to full voltage.

The single pulse current rating of MOSFET is important when a short-circuit takes place. The MOSFET must survive a 15ms overload. MOSFETs of lower $R_{DS(ON)}$ or MOSFETs that use more powerful thermal packages will have a high power surge rating. Using too small of a pulse rating will allow the MOSFET to blow to the open circuit condition instantly like a fuse. Typically there is no outward sign of failure because it happens so fast. Please measure the surge current for all discharge power paths under worse case conditions and consult the MOSFET data sheet for the limitations. Voltage sources with the highest voltage and the most bulk capacitance are often the biggest risk. Specifically the MOSFETs in the wall adapter path with wall adapters of high voltage, large bulk capacitance and low resistance DC cables between the adapter and device are the most common failures.

Remember to *only* use the *real*/wall adapter with a production DC power cord when performing the wall adapter path test. The use of a laboratory power supply is unrealistic for this test and will force you to over specify the MOSFET ratings. A battery pack usually has enough series resistance to limit the peak current or are too low in voltage to create enough instantaneous power to damage their respective power path MOSFETs.

Conditioning Systems With Large Loads

In systems where the load is too large to be used for conditioning a single battery it may be necessary to bypass the built in calibrate function and simply switch in an external load. A convenient way to accomplish this task is by using an SMBus based LTC1623 load switch controller. See Figure 10.

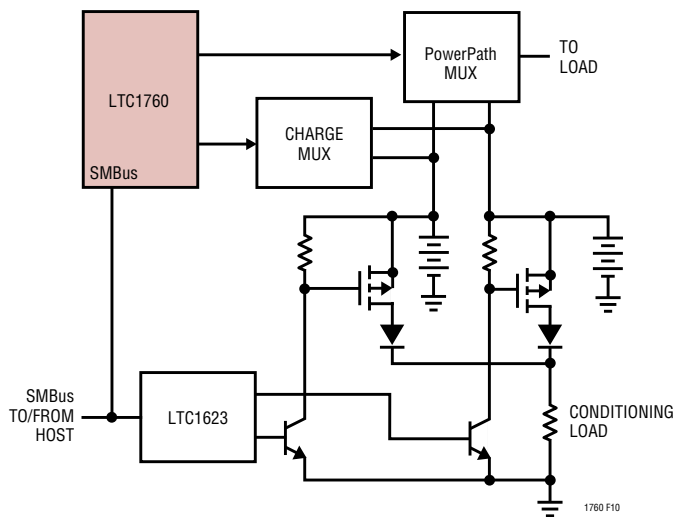

Figure 10. Large Load Conditioning Circuit

Unique Configuration Information

This section summarizes unique LTC1760 configurations that allow some LTC1760 features to be eliminated. These configurations may be selected in any combination without adversely affecting LTC1760 operation. Refer to the Typical Application circuit diagram located at the back of this data sheet.

APPLICATIONS INFORMATION

A) Single Battery Configuration.

To limit the LTC1760 to a single battery, modify the battery slot to be eliminated as follows:

- 1) Remove both FETs (Q5, Q6 or Q7, Q8) involved in the discharge path.
- 2) Remove both FETs (Q3, Q4 or Q9, Q10) involved in the charge path.
- 3) Remove the thermistor sensing resistors (R1A, R1B or R2A, R2B).
- 4) Short the thermistor sense lines (TH1A, TH1B or TH2A, TH2B) together at the IC.
- 5) Remove the diode (D2 or D3).
- 6) Unless otherwise specified, leave the unused pins of the LTC1760 floating.

B) No Short-Circuit Protection Configuration.

- 1) Replace R_{SC} with a short.

C) No LOPWR Protection.

- 1) Remove resistors R2 and R3 connected to LOPWR and tie LOPWR to the V_{CC} pin.

D) No DC Path Configuration.

To remove the DC input as part of the power path choices to support the load:

- 1) Remove both FETs Q1 and Q2 involved in the DC path.
- 2) Unless otherwise specified, leave the unused pins of the LTC1760 floating.

E) No Charge Configuration.

To permanently disable the battery charger function:

- 1) Remove ALL FETs involved in the charge path (Q3, Q4, Q9, Q10).
- 2) Remove switching FETs QTG, QBG, diode D1 and inductor L1.
- 3) Remove diodes D2, D3, D4, capacitors C4, C_{OUT} and Resistor R11 and R_{SENSE} .
- 4) Reduce C_{IN} capacitor to 0.1 μ F.

- 5) Remove all components connected to COMP1, V_{SET} , I_{TH} , I_{SET} , I_{LIMIT} and V_{LIMIT} pins.

- 6) Short I_{LIMIT} and V_{LIMIT} to GND.

- 7) Remove R1, C1 but short CLP to DCIN. Replace R_{CL} with a short/trace connection.

- 8) Short CSP to CSN but leave the combination floating.

- 9) Unless otherwise specified, leave the unused pins of the LTC1760 floating.

F) No DC Path And No Charge Configuration.

To limit the LTC1760 to battery discharge functions only, merge the previous two configurations with the following:

- 1) Remove C_{IN} .
- 2) Remove resistors tied to DCDIV. Ground DCDIV.

PCB Layout Considerations

For maximum efficiency, the switch node rise and fall times should be minimized. To prevent magnetic and electrical field radiation and high frequency resonant problems, proper layout of the components connected to the IC is essential. (See Figure 11.) Here is a PCB layout priority list for proper layout. Layout the PCB using this specific order.

1. Input capacitors need to be placed as close as possible to switching FET's supply and ground connections. Shortest copper trace connections possible. These parts must be on the same layer of copper. Vias must not be used to make this connection.

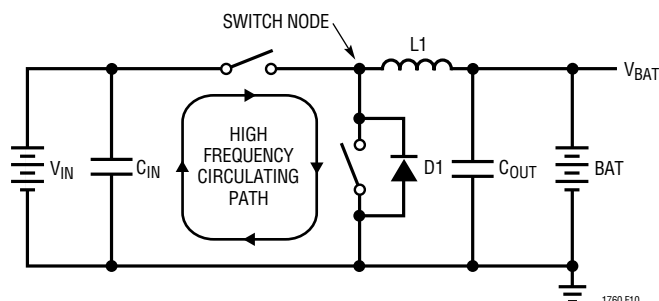

Figure 11. High-Speed Switching Path

APPLICATIONS INFORMATION

- The control IC needs to be close to the switching FET's gate terminals. Keep the gate drive signals short for a clean FET drive. This includes IC supply pins that connect to the switching FET source pins. The IC can be placed on the opposite side of the PCB relative to above.
- Place inductor input as close as possible to switching FET's output connection. Minimize the surface area of this trace. Make the trace width the minimum amount needed to support current—no copper fills or pours. Avoid running the connection using multiple layers in parallel. Minimize capacitance from this node to any other trace or plane.
- Place the output current sense resistor right next to the inductor output but oriented such that the IC's current sense feedback traces going to resistor are not long. The feedback traces need to be routed together as a single pair on the same layer at any given time with smallest trace spacing possible. Locate any filter component on these traces next to the IC and not at the sense resistor location.
- Place output capacitors next to the sense resistor output and ground.
- Output capacitor ground connections need to feed into same copper that connects to the input capacitor ground before tying back into system ground.
- A good rule of thumb for via count for a given high current path is to use 0.5A per via. Be consistent.
- If possible, place all the parts listed above on the same PCB layer.
- Copper fills or pours are good for all power connections except as noted above in Rule 3. You can also use copper planes on multiple layers in parallel too—this helps with thermal management and lower trace inductance improving EMI performance further.
- For best current programming accuracy provide a Kelvin connection from R_{SENSE} to CSP and BAT. See Figure 12 as an example.

It is important to keep the parasitic capacitance on the R_T , CSP and BAT pins to a minimum. The traces connecting these pins to their respective resistors should be as short as possible.

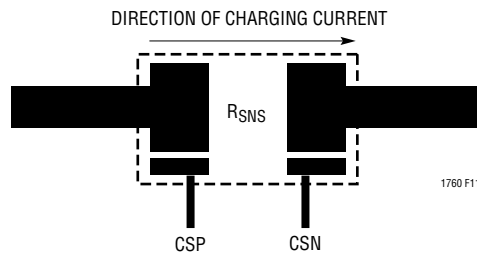

Figure 12. Kelvin Sensing of Charging Current

General Rules

- Connection of switching ground to system ground or internal ground plane should be single point. If the system has an internal system ground plane, a good way to do this is to cluster vias into a single star point to make the connection.
- Route analog ground as a trace tied back to IC ground (analog ground pin if present) before connecting to any other ground. Avoid using the system ground plane. CAD trick: make analog ground a separate ground net and use a 0Ω resistor to tie analog ground to system ground.

Important Safety Notes

Although every effort is made to meet and exceed all required “SMBus Charger V1.1” safety features it is the responsibility of the battery pack to protect itself from excessive currents or voltages. The LTC1760 is not itself a safety device. Consult your battery pack manufacturer for more information.

TYPICAL APPLICATIONS

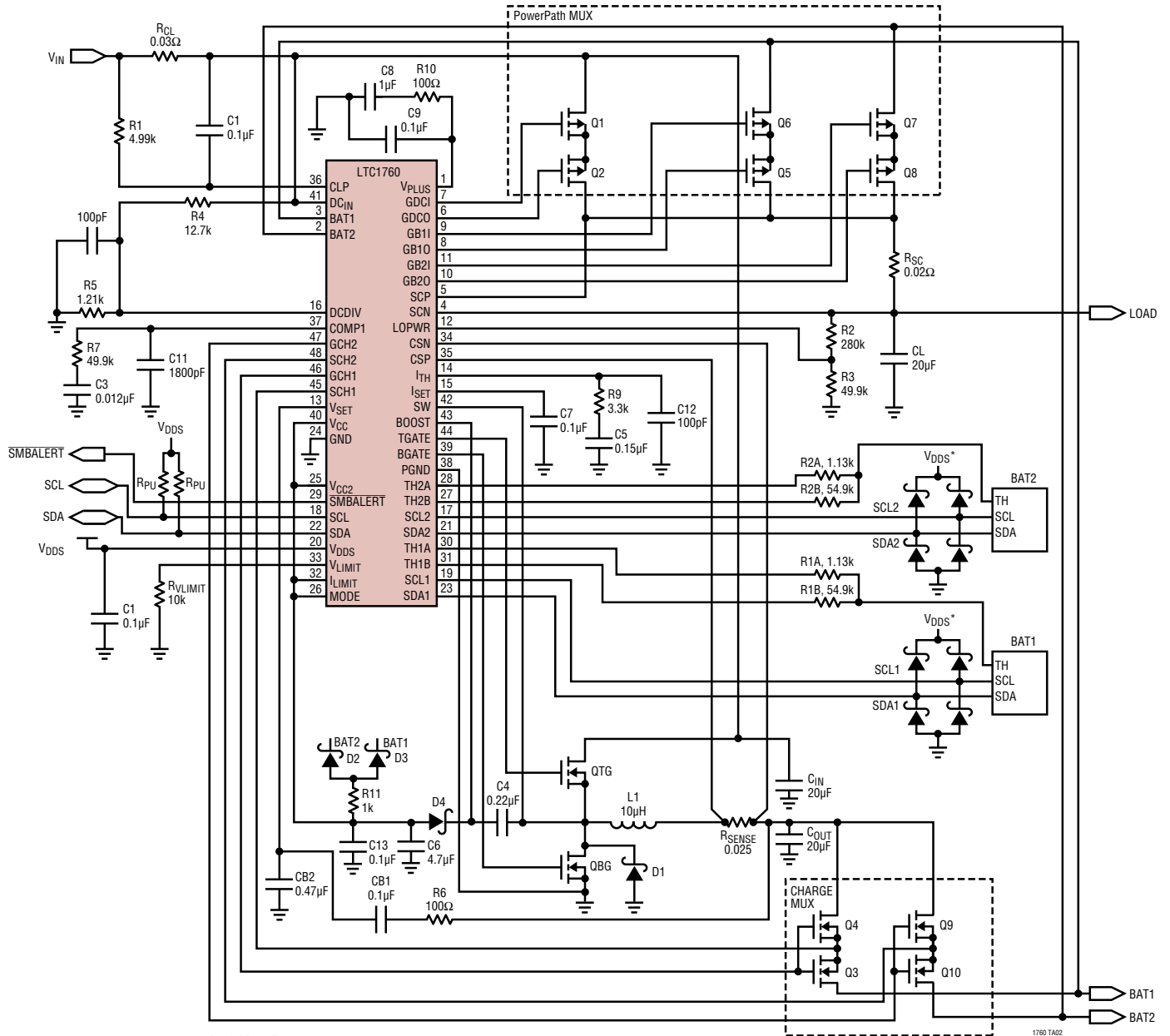

- D1: MBR130T3
- D2, D3: BAT54A TYPE
- D4: CMDSH3 TYPE
- Q1, Q2, Q5, Q6, Q7, Q8: Si4925DY
- Q3, Q4, Q9, Q10, QTG, QBG: FDS6912A
- *OPTIONAL: ESD CLAMP DIODES FOR BATTERY HOT SWAP PROTECTION

PACKAGE DESCRIPTION

Please refer to <http://www.linear.com/product/LTC1760#packaging> for the most recent package drawings.

FW Package
48-Lead Plastic TSSOP (6.1mm)
 (Reference LTC DWG # 05-08-1651 Rev A)

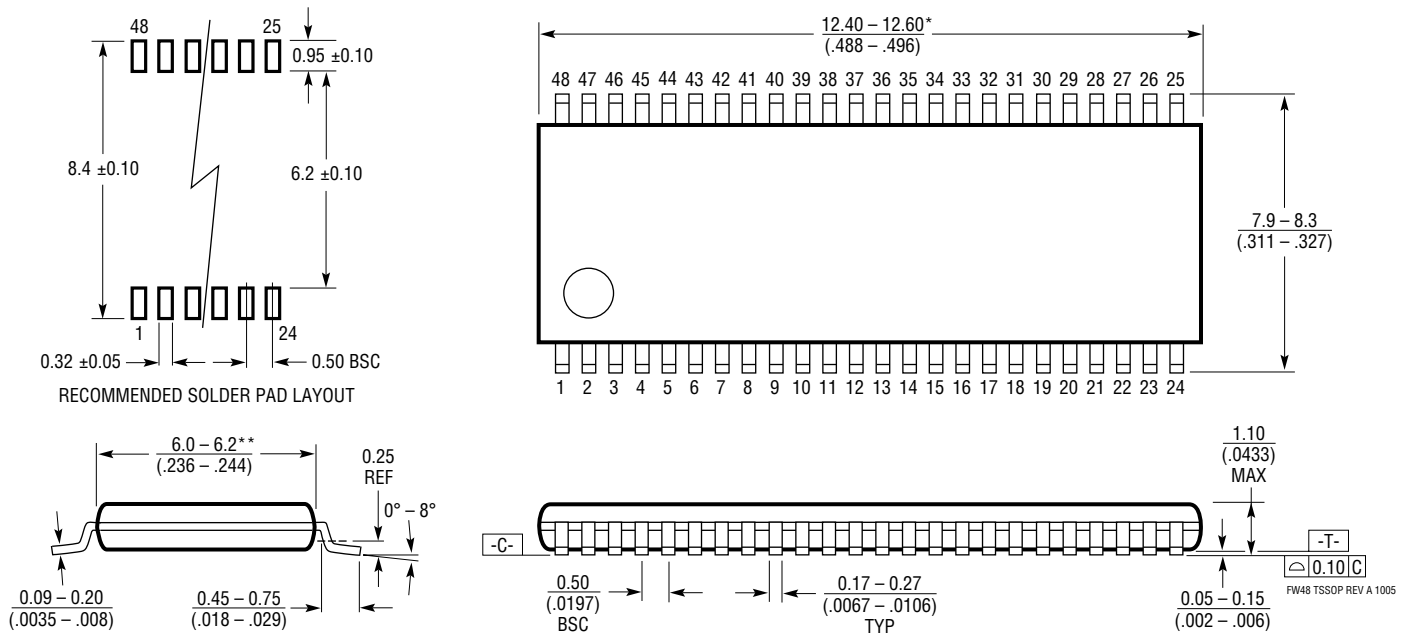

NOTE:

1. CONTROLLING DIMENSION: MILLIMETERS

2. DIMENSIONS ARE IN $\frac{\text{MILLIMETERS}}{\text{(INCHES)}}$

3. DRAWING NOT TO SCALE

*DIMENSIONS DO NOT INCLUDE MOLD FLASH. MOLD FLASH SHALL NOT EXCEED .152mm (.006") PER SIDE

**DIMENSIONS DO NOT INCLUDE INTERLEAD FLASH. INTERLEAD FLASH SHALL NOT EXCEED .254mm (.010") PER SIDE

REVISION HISTORY

REV	DATE	DESCRIPTION	PAGE NUMBER
A	04/11	I-Grade part added. Reflected throughout the data sheet	1-48
B	03/16	Revised Conditions of V_{CC} Load Regulation Spec	3
C	08/17	Revised Circuit Diagram C5 & C7, BAT1, BAT2 added	45

RELATED PARTS

PART NUMBER	DESCRIPTION	COMMENTS
LT[®]1571	1.5A Switching Regulator Battery Charger	500kHz or 200kHz Switching Frequency for Small Design
LTC1733	Li-Ion Linear Charger with Thermal Regulation	Will Not Overheat, Standalone Charger, Complete Charger
LT1769	2A Switching Regulator Battery Charger	Monolithic, 20-Lead TSSOP, 28-Lead SSOP Packages
LTC1960	Dual Battery Charger/Selector with SPI	11-Bit V_{DAC} , 0.8% Voltage Accuracy, 10-Bit I_{DAC} for 5% Current Accuracy
LTC4006	Small, High Efficiency, Fixed Voltage, Lithium-Ion Battery Charger	Constant Current/ Constant Voltage Switching Regulator with Termination Timer; AC Adapter Current Limit and SafetySignal Sensor in a Small 16 Pin Package
LTC4007	High Efficiency, Programmable Voltage Battery Charger with Termination	Complete Charger for 3- or 4-Cell Lithium-Ion Batteries, AC Adapter Current Limit, SafetySignal Sensor and Indicator Outputs
LTC4008	High Efficiency, Programmable Voltage/Current Battery Charger	Constant Current/ Constant Voltage Switching Regulator; Resistor Voltage/Current Programming, AC Adapter Current Limit and SafetySignal Sensor
LTC4100	Smart Battery Charger Controller	SMBus Rev 1.1 Compliant